

# LIGHTING+**SOUND** *International*

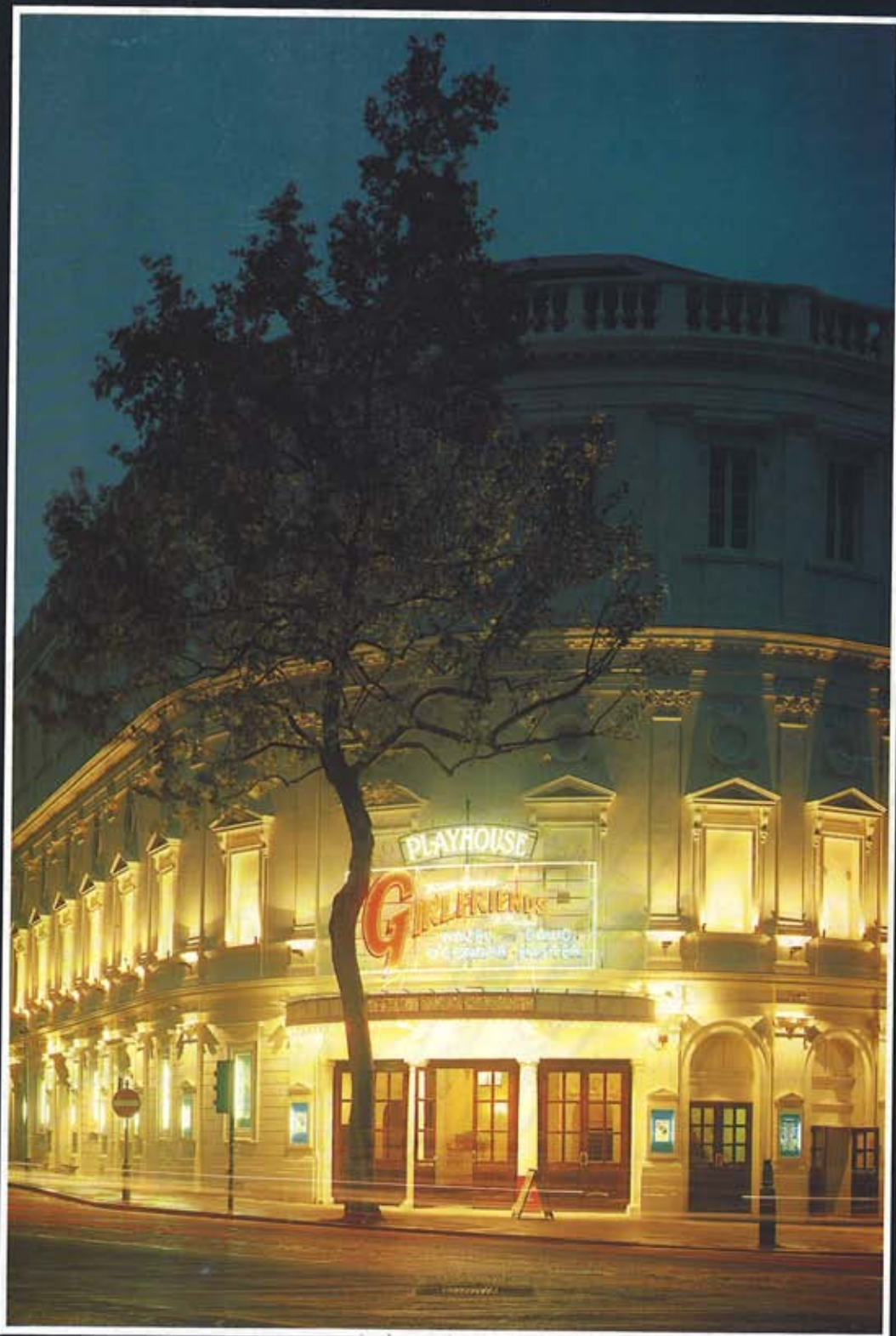

The Playhouse lives again in London's West End - see feature this issue.

**PLASA**

Published by the Professional Lighting and Sound Association

**November 1987**  
Volume 2 No.10

**£1.50**

**VERLINDE**  
THE  
INDUSTRY  
STANDARD

WE SUPPLY  
COMPLETE MOTOR  
SYSTEMS,  
INCLUDING  
CONTROL  
CABLING AND  
FLIGHT CASES—AS  
WELL AS A WIDE  
RANGE OF RIGGING  
HARDWARE

TO RECEIVE A COPY  
OF OUR ILLUSTRATED  
BROCHURE, CALL US NOW



**MODERNWORLD**  
**LIGHTING LTD**  
ENTERTAINMENT SALES

UNIT 1 • BABBAGE ROAD • STEVENAGE • HERTS • SG1 2ED • ENGLAND  
TELEPHONE: (0438) 317200 • TELEX: 265871 REF DG51518 MONREF G • E-MAIL: DGS 1517

---

**LUFF**  
**LIGHT & SOUND**

For hire, sale, and service.  
Strand and Quartzcolor lighting  
Environ architectural dimming  
Colour filters, gobos, and effects  
Bose, Harrison, Soundcraft,  
Yamaha, AKG and Shure etc.

36-38 Gautreay Road, Nunhead, London SE15 2JQ.

**01-639 6911 HIRE**  
**01-639 7705 SALES**

Service either number or Vodafone  
0836 231125

**Strand Lighting** **BOSE**  
Main Distributors

**TRILITE**  
STRUCTURAL SYSTEM



Trilite is a lightweight,  
aluminium structural  
system. Compact  
and modular, the  
system combines  
ease of assembly  
with excellent  
load-bearing  
capabilities.

With an  
appearance that  
attracts attention,  
Trilite can define  
space and area for  
a variety of applic-  
ations. Its inherent  
strength can be utilised  
to mount lighting, sound,  
video or other display equipment.

For Further Information Contact:  
**OPTIKINETICS**  
38 Cromwell Road  
Luton LU3 1DN England  
Telephone (0582) 411413  
Telex 825920 OPTI S G



# Presenting the NEW Silhouette range ...



Silhouette 2000

Silhouette 1200

Silhouette Axial 1000

## ... from CCT – still no. 1 in profile spotlights.

With its *new* Silhouette range, CCT covers a broader range of professional user requirements for profile spotlights than any other lighting manufacturer.

Two of the three lamphouses in the Silhouette range are completely new. There are seven fully interchangeable lens tubes and the widest range of accessories on the market. What's more, Silhouette spotlights will give you *more light* than any comparable product you could name!

Whichever way you look at it, the Silhouette range *has to be first choice*, for breadth of applications, flexibility and sheer performance.

For more information – and for up to date performance data comparing Silhouettes with other products – contact CCT today!

### **NEW**

#### **Silhouette 2000**

- A completely new 2000W lamphouse.
- New high efficiency reflector with peak/flat lead screw trim.
- New extrusions and construction.
- Superb performance.
- Fast-fit snap on lens tube accessory option.

### **NEW**

#### **Silhouette 1200**

- Smaller. Lighter. Brighter.
- 1000W or 1200W.
- New high efficiency reflector with peak/flat trim.
- Fast-fit snap on lens tube accessory option.

#### **Silhouette Axial 1000**

- Axially mounted lamp.
- Peak/flat beam control.
- Exceptional performance.
- Fast-fit snap on lens tube accessory option.

For maximum performance choice and flexibility, the Silhouette range features seven interchangeable lens tubes – five zoom and two non-zoom, narrow angle and extra narrow angle.

**CCT**

**theatre lighting**

WINDSOR HOUSE 26 WILLOW LANE MITCHAM SURREY CR4 4NA Tel: 01-640 3366 Telex: 946648

Update your existing Mk2 and Mk3 Silhouettes and Starlettes to take **NEW** 1200W or 1000W lamps. PLUS easy-fit, snap on lens tube and accessory for all Silhouettes – past and present.

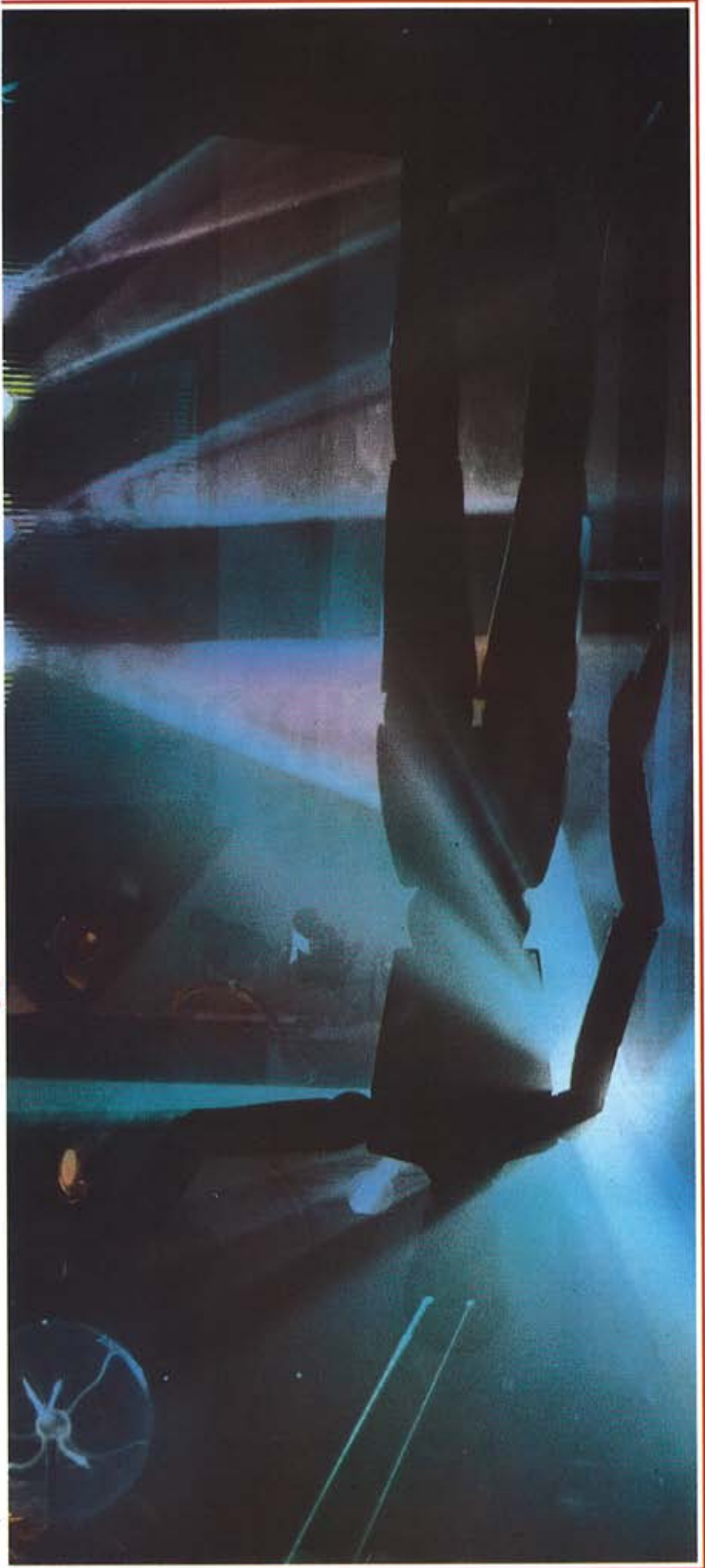

NAME: \_\_\_\_\_  
 (Title, Initial, Surname)  
 JOB TITLE: \_\_\_\_\_  
 COMPANY: \_\_\_\_\_  
 ADDRESS: \_\_\_\_\_  
 TELEPHONE: \_\_\_\_\_

Effects Lighting (Leicester) Limited  
 928 Melton Road, Thurmaston,  
 Leicester LE4 8GR  
 Telephone: (0533) 601271

PLEASE SEND ME DETAILS

NAME: \_\_\_\_\_  
 (Title, Initial, Surname)  
 JOB TITLE: \_\_\_\_\_  
 COMPANY: \_\_\_\_\_  
 ADDRESS: \_\_\_\_\_  
 TELEPHONE: \_\_\_\_\_

W/B Lighting Limited  
 4 Tenter Road, Moulton Park Ind. Est.,  
 Northampton NN3 1PZ  
 Telephone: (0604) 499331

PLEASE SEND ME DETAILS

**COEMAR**

LIGHT ■ the agent that stimulates the sense of sight, a kind of radiation. ■ the presence or amount or effect of this. ■ a source of light, especially an electric lamp, *leave the light on*. ■ a flame or spark, something used to produce this. ■ brightness, the bright parts of a picture etc. ■ enlightenment; *light dawned on him*, he began to understand. ■ the aspect of something, the way it appears to the mind, *see the matter in a different light*. ■ a window or opening to admit light. —*light adj.* ■ full of light, not in darkness. ■ pale, *light blue*. —*light v.* (lit. lighted 'I see note at end of entry), lighting) ■ to set burning, to begin to burn, to cause to give out light. ■ to provide with light, to guide with a light. ■ to brighten, □ *bring or come to light*, to reveal or be revealed, to make or become known. **In the light of this**, with the help given by these facts. **light**





# LIGHTING+SOUND *International*

## NOVEMBER 1987

- |    |  |
|----|--|
| 6  | NEWS in Lighting + Sound International |
| 13 | Playhouse Plush                        |
| 19 | Stompin' at the Savoy                  |
| 23 | Training for the Future?               |
| 27 | Midnight's Variety                     |
| 31 | Show Page with PLASA News              |
| 33 | On Tour                                |
| 36 | Equipment News                         |
| 39 | Directory                              |
| 46 | PLASA Members                          |



A video shoot at the Astoria, London — see Midnight's Variety feature pages 27-29.

## LIGHTING+SOUND *International*

published by the  
Professional Lighting and Sound Association

Editor: John Offord

Telephone: (0323) 642639

Telefax: (0323) 646905

PLASA office:  
7 Highlight House, St. Leonards Road,  
Eastbourne, Sussex BN21 3UH.  
Telephone: (0323) 410335



© Copyright Professional Lighting & Sound Association  
No part of this magazine may be reproduced without the permission of  
the Editor.

Annual Subscriptions:  
UK £20.00; Europe £25.00; airmail £40.00.

## Silhouettes March On

CCT's new 'compact' Silhouette 3 profile - design-  
ed to take both the 1000W T11/T19 and 1200W  
T29 lamps.



Once again CCT seem to have maintained their  
reputation for innovation and for listening to their  
customers.

The ABTT Trade Show North will see the in-  
production of their latest Silhouette profile spot.  
Designed to take both the 1000W T19 and  
1200W T29 lamps, it has been shortened to  
195mm in length. It uses CCT's latest high perfor-  
mance reflector, making it the most compact, effi-  
cient and flexible profile spotlight available say the  
company.

It can be used with any of the five zoom and two  
non zoom Silhouette lens tubes, and for those  
users who want it, an accessory pack is available  
which can be fitted in a couple of minutes to give  
a 'Fastfit' snap-on lens tube facility which also pro-  
vides for shutter rotation. This Fastfit accessory  
can be fitted to any CCT Silhouette 2000, keeping  
alive the promise that CCT always try to design  
improvements to their Silhouette range so that  
they can be applied to earlier generations of pro-  
duct.

For users who have MK2 and MK3 Silhouettes,  
CCT now have available update plug-in lamprays  
to allow the choice of either 1000W T19 or  
1200W T29 lamps. A similar lampray update

The re-designed Silhouette 2000, with increased  
light output.



complete with reflector is available for Starlette  
Fresnel and Pebble spots.

Also to be shown by CCT at the ABTT North  
Show will be their completely re-designed 2000W  
Silhouette. It is a great improvement over any  
other 2000W profile and is in growing demand by  
theatre and television professionals.

CCT's Phil Rose told L+S that their latest con-  
densor lensed 650W followspot, shown for the  
first time earlier this year, is attracting a good deal  
of attention, being ideal for club and disco work  
and economically priced.

The latest control from AVAB, represented by  
CCT in the UK, is the 211. Available for 24-48-72  
channels it is a powerful and flexible system well  
suited for the theatre and most demanding of  
club, disco and musical productions. Full technical  
and performance information is available from  
CCT and, for those considering a new control  
system, it is well worth study.

Picture above is the update kit for the Starlette  
1KW fresnel, showing (left) positioned to take the  
1200W T29 lamp and (right) the 1000W T11/T19  
lamp.

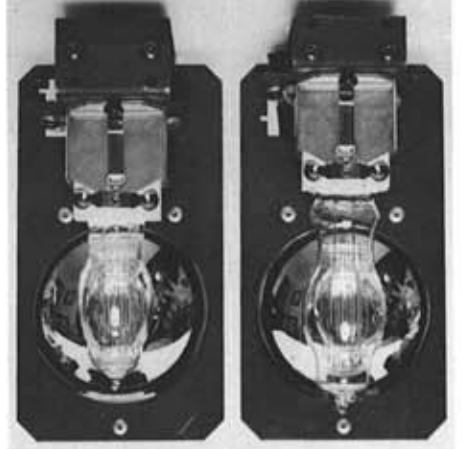

The CCT accessory kit can be used to update any  
Silhouette profile manufactured within the last 10  
years, and includes the facility for rotatable shut-  
ters, quick release of lens tube from lamphouse,  
and accommodation for the new lamp trays.

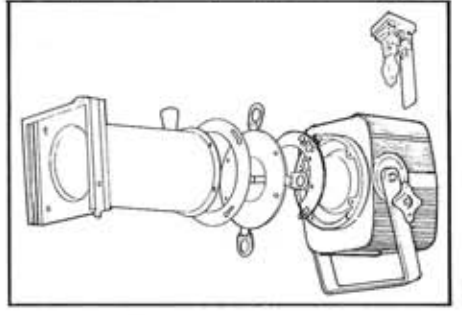

# METEORLITES

U.K. TEL: (0438) 317200 TELEX: 265871 REF. DGS1518 MONREF G E-MAIL: DGS1518  
U.S.A. TEL: (301) 733 3855 TELEX: 4900001631 MET UI E-MAIL: IMC 1796

CONCERT, TV, AND STAGE LIGHTING AND PRODUCTION



Hurricane Hits Le Maitre

Le Maitre Lighting and Effects' hire shop took the  
brunt of the recent hurricane, and the prominent  
corner site is now closed pending demolition. All  
business is now being dealt with from the com-  
pany's 316 Purley Way address.

## Eagle Trust bid for Samuelson Group

A takeover bid for the Samuelson Group plc has  
been received from Eagle Trust plc. It has been  
recommended unanimously by Samuelson's  
board of directors.

Eagle Trust is a diversified Birmingham-based in-  
dustrial conglomerate, with a market capitalisa-  
tion of approximately £250 million, and a debt-  
free balance sheet. "This prodigious financial  
resource will enable the Samuelson Group to  
grow and prosper by making available to us the  
capital necessary to fully exploit the business op-  
portunities which occur in some highly com-  
petitive fields," said Sydney Samuelson, chairman  
of the Samuelson Group.



CD Sound from TSL

Theatre Sound and Lighting Services are now  
stockists for 'Digiffects', the world's first and only  
real digital sound effects library.

These compact discs produce crystal clear  
3D-sound, as all effects are digitally recorded, mix-  
ed and mastered. Ten different categories are  
available plus a cross-section disc which contains  
selections from all ten categories. All discs can be  
purchased singly at only £40 each plus VAT.

For further information and a fully descriptive  
brochure contact the TSL sales office at 67 Drury  
Lane, London WC2B 5SP telephone 01-836 6902  
or 01-836 7877.

TSL have also announced that they now stock  
the 'Avri Top System' lighting track, and technical  
broadsheet showing the complete range plus  
accessories is also available from their Drury Lane  
office.



## AJS Move out of Town

From 2nd November AJ'S Theatre Lighting and Stage Supplies Limited will be operating from their new purpose built premises at Ringwood in Hampshire.

The Company decided to move only last January when managing director Adrian Sant was offered the chance to purchase a suitable plot of land on the same estate as Doughty Engineering at Ringwood. Drawings and planning permission were rapidly obtained, local builders George and Harding appointed and given until the 17th October to complete the project.

The move itself was carried out over two weeks commencing Monday 21st October, during which it was 'business as usual! The new premises feature greatly improved loading facilities, a separate bay for hire and sales and easier parking for visitors. A new demonstration studio is being equipped over the next few months, and this will be ready in time for the official opening of the premises during the spring of 1988.

The new address is - Hightown Industrial Estate, Crow Arch Lane, Ringwood, Hants BH24 1ND, telephones (0425) 470888 (sales), (0425) 470088 (hire), and (0425) 470425 (administration).

## Farrah + Soundcraft

Over the last six months Paul Farrah has taken delivery of no less than 100 Soundcraft mixing consoles! These consist of all configurations, and include the updated Series 8000, now incorporating channel VCA sub-grouping, and Series

500 monitor desks which were launched earlier this year.

Recent Farrah contracts included the Labour Party's annual Brighton Conference at the end of September, where they supplied a Series 200B 24-channel desk to MBI, the Brighton hire and sales company which looked after all on-site sound reinforcement. In another deal, Wigwam



**32, 34 AVON TRADING ESTATE,  
AVONMORE ROAD,  
LONDON W14 8TS**

**TRADE COUNTER**  
Open 24 hours a day 7 days a week.  
Immediate Delivery in London Area.

Large range in stock including:  
G.E., Thorn, Philips, Lee, Rosco,  
Chris James, Socapex, Neutrix,  
Duraplug, Thomas, Strand, CCT,  
Rosco, Le Maître.

**TELEPHONE:  
01-603 9831  
OR  
01-602 7932**

Acoustics, who have been installing a new sound system at Croydon's Fairfield Halls, recently took delivery of two Soundcraft desks from Paul Farrah - a 24 channel Series 500 for on-stage monitoring, and a 32-channel Series 8000 for front-of-house.

## Move for Grapevine

Grapevine Sound and Light are now based in the Wimborne area in Hampshire in far superior premises on the Ferndown Industrial Estate.

Their new address is Enterprise House, 10 Whittle Road, Ferndown Industrial Estate, Wimborne, Dorset BH21 7RL telephone (0202) 893665.

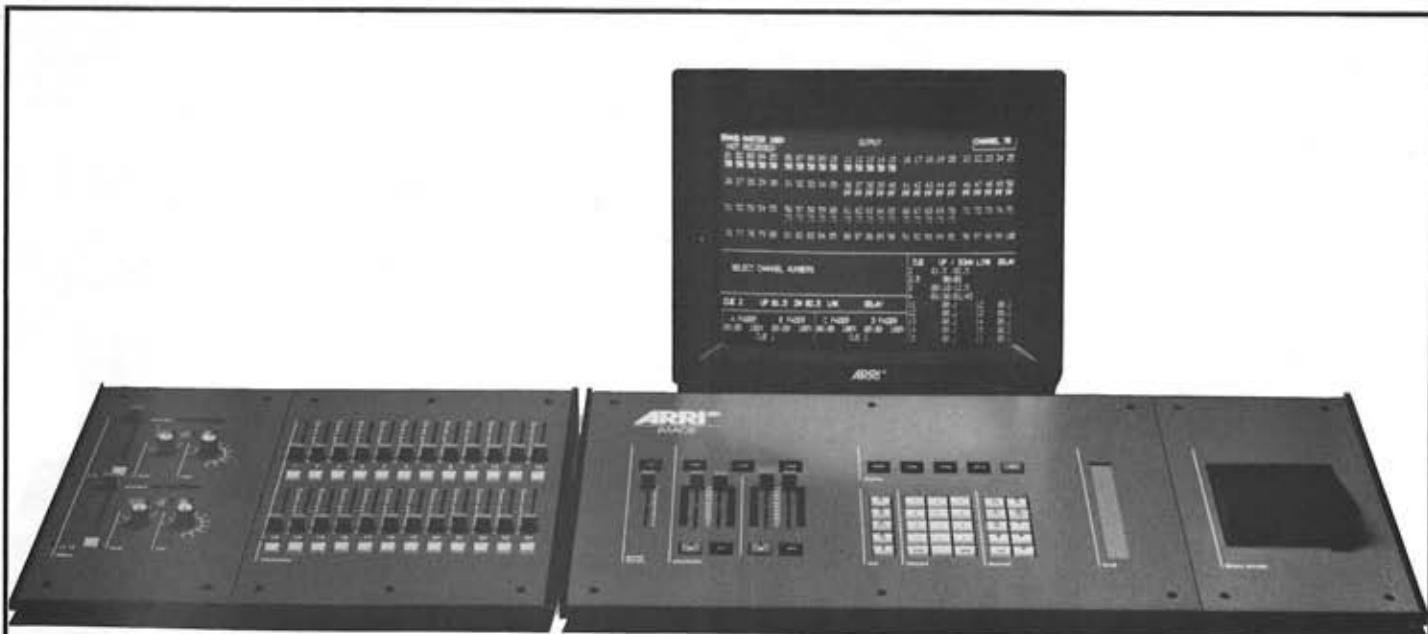

Working with imagination gets the best out of your **IMAGE**

Telephone for Hire or Sales: London 01-965 8188 Manchester 061-793 5848





# Scene 1: A beautifully lit set anywhere in Britain



Put yourself in control with Lee Colortran International's range of lighting consoles and dimmer systems.



Prestige 2000C

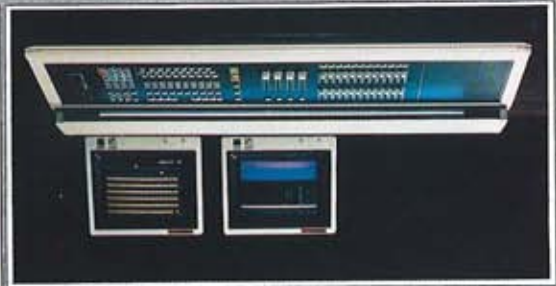

Prestige 3000



TriMaster



SceneMaster 60

The Prestige series takes microprocessor-based lighting control systems forward to a new level. Designed the way you asked, Prestige 1000, 2000 and 3000 are easy to use, yet give more features and more confidence – with less bulk and weight. SceneMaster 60 combines memory and manual systems to give versatility to lighting designs. And TriMaster keeps you in control of three scenes from a lightweight console. Match your creativity with technical excellence. Ask for Lee Colortran – and put yourself in control.

# LEE Colortran International®

United Kingdom □ United States □ West Germany  
France □ Spain □ Hong Kong □ New Zealand

**LEE Colortran Ltd.**

Lodbrooke Hall, Borby Road, London W10 5HH Tel: 01-968 7000 Fax: 01-960 2393  
Lynxun Trading Estate, Old Wellington Road, Eccles, Manchester M30 9GD  
Tel: 061-788 0174 Fax: 061-789 0484



Ask About  
the Magic Sheet  
Option



## Fifteen Years from Zero

On October 28th 15 years ago, Zero 88 Lighting Limited was founded by four engineers who whilst at Brunel University found they had a common interest in the entertainment lighting industry. Peter Brooks, Chris Fenwick, Alan Munton and Richard Thornton-Baker took on a shop in Hatfield Road, St. Albans and established a small manufacturing facility. From the very first they built their reputation on quality of design and high standards of construction.

By 1976 their discotheque products were well established, and they had developed and patented the well known Cartridge Effects system - a system that has found favour with users in television, theatre, schools and night-clubs. Admired for its quality and simplicity of use, variations of this versatile controller are still produced today.

Past products have included the 3600 series of modular, three pre-set lighting control boards (forerunner of the Eclipse) and the seemingly indestructible Lightmaster 690 and 691 dimmer racks. More recently Zero 88 have been at the forefront of the movement to introduce microprocessor assisted controllers into the night-club, discotheque and theatre market-places. The legendary MDS (Multi Dimensional Controller) was the very first microprocessor-based controller in the discotheque market. This was closely followed by the Micro 4, FX3 and FX4.

Even from the early years Zero 88's commitment to serving demands for quality led the company into the export field. Today, some 75% of output goes overseas to Europe, the USA, where Zero 88 Inc has been established over 2 years, the Middle and Far East. An understanding of local market requirements and local electrical and safety standards has been absolutely essential to this push towards exports; consequently Zero 88 personnel are often spotted on overseas trips and are in regular attendance at international exhibitions, either with their own stand or supporting an overseas agent.

Current products now include the award-winning microprocessor-based Mercury system for night-clubs and discotheques, the Lightmaster 1200, now the highest selling small memory control board in history, and, of course, flagship of the fleet, the Eclipse modular professional lighting desk with some 350 installations world-wide to its credit. For each of these products Zero 88 produce a wide range of dimming and switch packs and many accessories.

Zero 88 in 1987 is a very different company to the one that began life 15 years ago. A visit to the factory in Hart Road, St. Albans shows it equipped to the highest standards with power-tools, assembly jigs, cable cutting and injection moulding machines. Computers are everywhere, in testing, stock control, accounts and even in design where two separate C.A.D. systems are operated.

However, one thing has not changed. Today more than ever before Zero 88 is committed to quality of design and manufacture with good back-up and service through its network of agents. So it is hardly surprising that the company continues to grow every year and has become a major force in the industry world-wide.

Under present directors Peter Brooks, Chris Fenwick, Freddy St. John Lloyd and Richard Thornton-Brown the total staff number 35, and Zero 88's development team is currently working on further new products which point towards some exciting releases in 1988.

Watch this space!



Introduced in 1972, the Lightmaster 300 was well known as an economic and reliable controller for mobile discos. Its natural successors were the Mercury and Zero 88's latest controller, the Orion (below).



The Lightmaster 681 (left) came on stream in 1975 and through natural development evolved to become the famous Eclipse modular lighting desk (right) which was introduced in 1983. The Eclipse now sells worldwide at the rate of over 100 units each year.



# Lights..... Sound..... Powerdrive....

In our showroom we have a pile of our new Powerdrive range brochures and you should really have one in your hands.

When it comes to rigging lights or speaker systems for just about any type of performance, Powerdrive stands represent the best value around. We have the fittings to make any of your ideas into a reality and we offer immediate availability through our world-wide distributor network. The Powerdrive range is a top quality, UK made product, robust, well finished, with ready spares availability. Clip the coupon and get Powerdrive into your act.

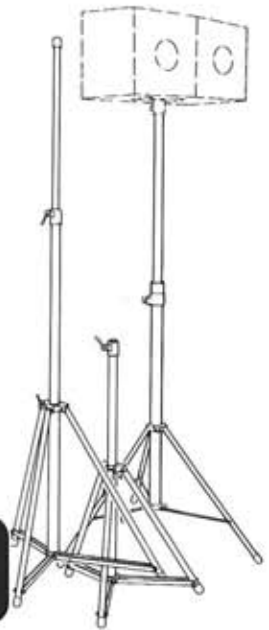

**POWER  
DRIVE**

Please send me my copy of the Powerdrive brochure and the name of my local Powerdrive distributor.

Name \_\_\_\_\_

Company \_\_\_\_\_

Address \_\_\_\_\_

Worldwide distribution: Cerebrum Lighting (Sales & Hire) Ltd., 'The Stage and Effects Lighting Centre', 168 Chiltern Drive, Surbiton, Surrey KT5 8LS, England.  
Tel: 01-390 0051/01-390 4841 Fax: 01-390 4938 Telex: 892337 (CELCO G).

Technically superior and totally dependable.  
MPX 9 - 31, better performance.



A SIGN OF QUALITY

CITRONIC

## MPX MIXERS

Video Software: Video Pool  
Mobile Lighting: JiveLight CR16 Mobile Harvester  
New Sound Equipment: Technics SL-P1200  
CD Player  
Microphone: Shure SM Series  
Design and Installation  
Club Design: LimeLight, London  
Lighting Design: Lightfactor for The Palace,  
Blackpool  
Club Image: Ficks, Brechin  
Installers: Carboro Sound Services  
Further awards were made in Records and Performance, Operations and Promotions and Special Award categories.

**DI Awards at Le Palais**  
Disco and Club Trade International's annual awards for 1987, presented at Le Palais during the recent PLASA Light and Sound Show, were as follows:  
Lighting Effect: Coemar Robot  
Lighting Controller: Light Processor Commander  
Laser Controller: Laser Systems Magnum  
Console: Citronic Trent II Thames II  
Loudspeaker: Electro-Voice Full Range  
Amplifier: Harrison Information Technology  
DSA Series  
Video System: Cameron Video Systems Videowall

Both companies say they intend to maintain their separate operations, separate company headquarters, separate product lines and product identities in a bid to improve market share at their competitors' expense and not their own.

**Fane + McKenzie**  
Two well-known UK chassis manufacturers, Fane Acoustics Limited and McKenzie Acoustics Limited have joined forces.  
The deal, until now a well kept secret, will see Fane Acoustics' parent company Audio Fidelity plc acquire control of McKenzie Acoustics and its product lines which include loudspeakers, loudspeaker enclosures, amplifiers and crossovers.

**Entertainment and Arts**  
PLASA will be among over 100 companies and organisations who will be displaying their products, services and acts at Entertainment and the Arts '87, this year's gathering of the entertainment industry to be held in Harrogate from 16-18 November.  
Manning the PLASA stand at different periods during the event will be L+S editor John Offord and secretary to the Association, Tony Andrew. (A complimentary admission ticket was included in our October issue.)

Soundtracs plc have just received their second Queen's Award for Export Achievement. Presenting the Award, representative Deputy Lieutenant David Jacobs DL, representing Her Majesty The Queen, spoke of the pleasure he had in making his first such presentation to a company so closely associated with his own profession of broadcasting, especially as it was one of just 120 similar awards to be presented for 1987.  
In his acceptance speech, Todd Wells, chairman and managing director of Soundtracs, referred to the efforts of the workforce, suppliers and of course the 39 distributors/agents worldwide, as a contributing factor to gaining the Award with particular reference to fellow directors John Carroll and John Stadius, and management staff including Colin Fosket, Howard Diver and Tony Roberts.

## Soundtracs' Second Queen's Award

Soundtracs' Todd Wells receives the Award from David Jacobs.



Award at Le Palais.  
Cameron Video Systems receives the company's Ten Carnegie, sales and marketing manager for





"225 units sold end of september 1987,  
only 1 year after its market entry".

## **S20** LIGHTING CONSOLE WITH MEMORY

To broaden the application range of this exceptional console, we added a few more features:

- A proportional soft-patch controlling up to 240 dimmers, any quantity of dimmers connected to any channel.
- A printer for hard copy of memory content.
- An infra-red remote control.
- Possibility of connecting a manual console, with direct recording into the memory of the S20.
- Cassette recorder for library storage.
- Several types of decoders:
  - portable unit for up to 30 dimmers.
  - rackmount modules, with screw or plug connections for up to 240 dimmers.

For further information, please contact your dealer.

**N.V. ADB SA**  
Leuvensesteenweg 585  
B-1930 Zaventem  
Belgium  
Tel. +32/2/722.17.11  
Tx 22154

**ADB-Sofair s.a.**  
47, rue de la Vanne  
F-92120 Montrouge  
France  
Tel. +33/1/42.53.14.33  
Tx 206428

**ADB-Sofair**  
218, Grande Rue de la  
Guillotière  
F-69007 Lyon  
France  
Tel. +33/78/58.46.50  
Tx 900264

**ADB GmbH**  
Dieselstrasse 4  
D-6052 Mühlheim am  
Main  
Deutschland  
Tel. +49/6108/66204-05  
Tx 4189103

lighting  
systems **ADB**

# NEW LAMPS FOR NEW SPOTLIGHTS

Setting new standards for theatre lighting today, are Strand's new Cantata spotlights designed for our new 1.2kW lamp. With 50% more usable light from Cantata's special optical design and the R.S.E.29 lamp, it offers a powerful lighting performance. Cantata features Strand's unique fully rotatable gate assembly; much acclaimed by the top lighting designers. Used with a standard lamphouse, the Cantata range of 3 profile spotlights has easily interchangeable lens tubes, from 11°/26°, 18°/32° to 26°/44°. The range is completed with the new Cantata PC and Fresnel lanterns.

## Strand Lighting



Reversible fork for barrel or stand mounting.

Adjustable suspension fork with new locking mechanism.

Lockable and fully rotatable gate.

Accepts iris and gobo accessories.

Smooth shutter blade movement.

Secure yet easily detached rear lamp housing.



### STRAND'S NEW 1.2kW LAMP IN STOCK NOW

2-position lamp base accepts Strand's new 1.2kW lamp or the conventional 1kW lamp.

Lamp height adjustable.



Five luminaires that cover all requirements.



CANTATA F CANTATA PC CANTATA 2644 CANTATA 18/32 CANTATA 11/26

### CANTATA ADVANCED LUMINAIRE DESIGN FROM STRAND

Standard colour runners.

New PC lenses.

Rotatable barn doors for Fresnel and P.C. versions.

Strand Lighting Limited, PO Box 51, Great West Road, Brentford, Middlesex TW8 9HR, United Kingdom  
Telephone: 01 560 3171 Telex: 27976

LOS ANGELES · NEW YORK · TORONTO · LONDON · PARIS  
BRAUNSCHWEIG · ROME · HONG KONG · MELBOURNE



# Playhouse Plush

Derek Gilbert charts the course to the October re-opening of London's Playhouse Theatre.

The return to public use of any derelict theatre is an exciting event, and should be the cause of a celebration. In the case of the London West End's Playhouse Theatre this is particularly so. The Playhouse's auditorium decor has been meticulously and tastefully restored to its original condition, and the front-of-house spaces altered and improved. Just as important, the stage and backstage areas have been completely modernised.

The Playhouse, sited in Northumberland Avenue adjacent to British Rail's Charing Cross Station, was designed by architects Fowler and Hill and first opened its doors to the public in 1882 as the Royal Avenue Theatre. In 1906/7 substantial rebuilding became necessary after part of the elevated station had collapsed during building works, causing fatalities and seriously damaging the theatre. The new interior was modelled in Franco-Venetian style, incorporating a number of unique features including open balustrades.

For many years the Playhouse was run by Gladys Cooper, at first in partnership and later as actor-manager, and a number of Somerset Maugham's plays were first performed in the venue. Among the celebrated actors who appeared there were Noel Coward, Laurence Olivier, Ivor Novello and Alec Guinness.

In 1951 it was taken over by BBC Radio, and for the next twenty-five years served as a venue for radio productions that required live audiences such as Hancock's Half Hour. By 1976, the theatre had become somewhat neglected during the radio phase and afterwards fell into a serious state of disrepair. Various proposals were put forward for restoration, conversion or demolition, and all fell by the wayside until 1981 when the site was purchased by property developer Robin Gonshaw. While possessing the natural astuteness of a developer, Gonshaw nevertheless had a long-standing love of theatre, and determined that any development that would take place should include a full restoration of the Playhouse.

After considerable dialogue with the planning authorities, a scheme was eventually approved whereby the Playhouse would be rebuilt with residential accommodation constructed above the theatre, to be supported by an independent steel structure built up through the theatre from new foundations. A narrow block would also be built immediately behind the stage to provide separate lift and staircase access to the flats, as well as providing a number of one-room studios together with ancillary theatre space at basement level. At the same time, the Playhouse's impressive Portland stone facade would be extended upwards to achieve an aesthetic integration between theatre and residential units.

Construction work started in mid-1986, and it has been closely supervised throughout by Robin Gonshaw and an extensive team of professional advisors. Incorporation of a substantial tonnage of steelwork into the theatre's structure created a number of major problems as well as causing delays to the rebuilding programme. Many imaginative and innovative solutions were found, necessitating considerable

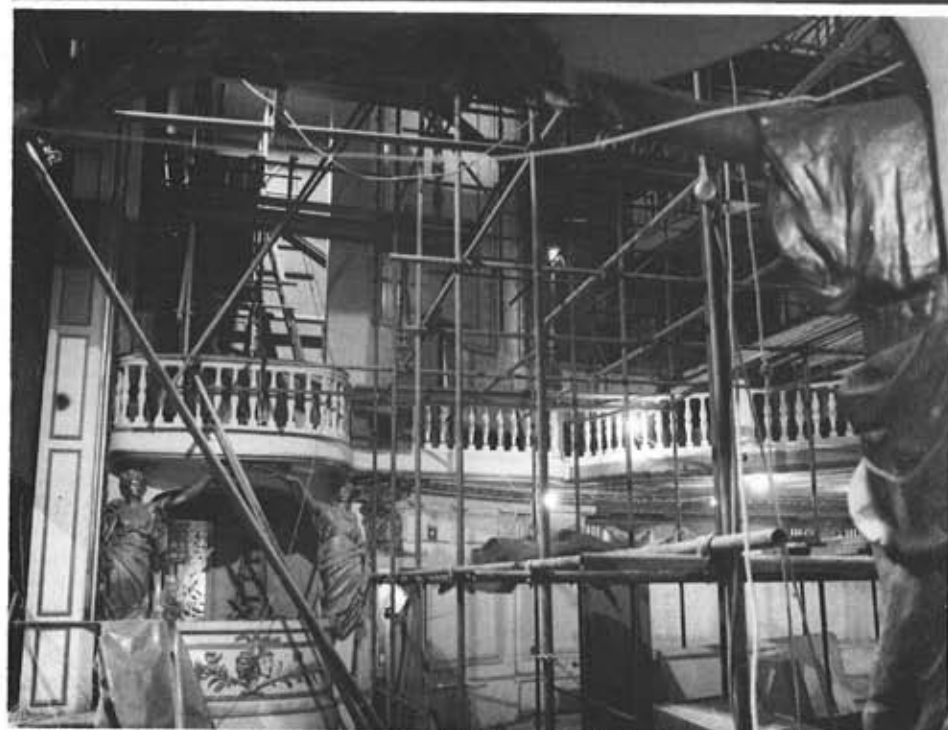

Construction work on the Playhouse began in mid-1986, and the theatre was re-opened in October 1987.



changes to the front-of-house areas but leaving the auditorium unaffected. Concealment of the steelwork has been carried out in an effective manner so that there is no intrusion and the general public are unaware of its existence.

The stage area, on the other hand, has been subject to extensive rebuilding. Although proscenium, side and rear walls have been retained, the timber grid and hemp flying sets have been completely replaced by a modern steel grid at a higher level, together with side and crossover galleries and 34 single purchase counterweight sets. Intricate and complicated design work was necessary to incorporate a smoke vent permitting smoke extraction through an opening in the flats being built above the fly tower. All stage engineering works including safety curtain renovation were carried out by P.E. Kemp (Engineers) Ltd. Understage the historically important timber stage machinery installation has been refurbished and one day parts of it may be

used in future productions.

Turning to systems and electrical installations, the original designs had been prepared by Theatre Projects Consultants against a brief that envisaged the Playhouse being occupied by a permanent resident theatre company. Plans changed however, and the provisions demanded by the brief had to be cut back to achieve compatibility with the budget available. During the implementation phase, ongoing consultancy and supervision services were provided by

Alive again! The Playhouse's auditorium decor has been meticulously and tastefully restored to its original condition.

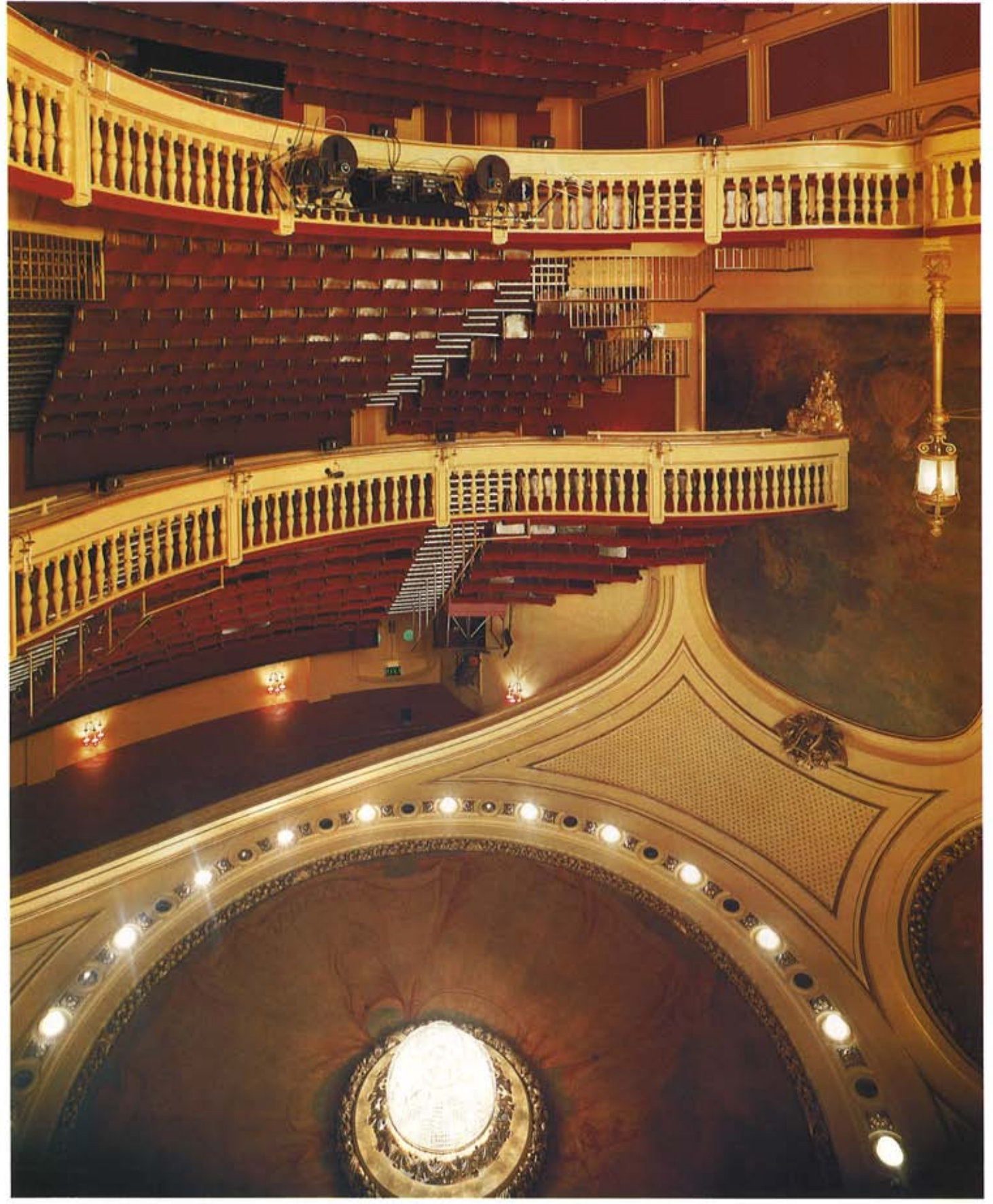



Charles Wass (theatre and stage equipment), Bob Anderson (electrical and stage lighting), Autograph (sound and communications) and Alan Todd (safety and licencing). A number of additional late requirements were injected by the user so that, throughout the project programme, the design process has been fraught with 'fluidity'.

In October 1986, a significant decision was taken to award to Glantre Engineering Limited a single contract covering supply, installation and commissioning of the complete electrical package for the Playhouse. This encompassed stage lighting, sound and communications, electrical power distribution, general lighting (interior, emergency and exterior) and all other electrical services for the building. The appointment of Glantre certainly produced considerable savings in co-ordination although it did not pass unnoticed that instead of the norm of one consultant and several contractors, the Playhouse electrical works involved several consultants but only one contractor!

The stage lighting installation is based on an 180 channel Strand Gemini control desk located in a miniscule control room at the rear of the dress circle but able to be brought out into the circle during rehearsal. The permanent stage dimmer installation consists of Strand Permus dimmers, 12 x 25 amp and 108 x 10 amp in 6 racks. The Playhouse's opening production, Howard Goodall's musical 'Girlfriends' demanded a heavy lighting rig requiring the basic dimmer installation to be supplemented by a further 48 x 10 amp dimmer in portable packs with demux units to permit control from the spare channels on the Gemini board. The production lighting wiring and socket installation is extensive with more than 60 of the dimmers being provided with two parallel connected pairs of 15A outlets to permit maximum flexibility. In addition, the modular socket boxes also incorporate outlets for 13 independent and 4 rehearsal light circuits.

No stage lighting luminaires are included in the initial scope of supply; it is intended that in accordance with normal West End theatre practice, these will be obtained on hire by the production company, thus providing the lighting designer with a complete freedom of choice. Mark Henderson's lighting rig for 'Girlfriends' comprises over 200 units on hire from White Light, and it was interesting to note that these included a considerable number of Pattern 264's - still performing well after many year's service - as well as Lekos of various beam angles. (The recent introduction of the latter to Strand Lighting's European catalogue is certainly much welcomed, as well as being long overdue.)

The Playhouse is provided with a full specification working light installation - a rare feature in a West End commercial theatre. The system possesses three operational modes - 'Day', 'Night' and 'Show'. Certain circuits are restricted to use in one mode only while others can be made available under two or all three. Under the Show mode, for example, backstage fluorescent fittings are inhibited. This eliminates the possibility of discovering that grid lights have been left on once the first fade to blackout is carried out! Main working light control panels are provided for stage manager and lighting operator with additional local push-button out-station controlling individual circuits at gallery and grid levels. The control rack, located in the dimmer room, incorporates electronic logic circuitry as well as all power contactors and fuses for working lighting, cleaners, independent and rehearsal



Safety in style - another view of the refurbished auditorium.

circuits. The working light control system was designed and built in-house by Glantre.

The sound installation is essentially a wiring, socket and patch panel infrastructure to accommodate a production hire sound rig. Fashions change fast in theatre sound, and the designer of any West End show will always require the freedom to select the most suitable equipment for their production - and this is particularly applicable in the case of mixers and loudspeakers. The advantages of providing an extensive sound wiring and connection network, as at the Playhouse, are to permit fast and easy fit-up as well as elimination of untidy temporary trailing cables, particularly to auditorium loudspeakers and the rear stalls mixer position.

In addition, the venue has been provided with a very basic set of sound equipment that should prove sufficient for straightforward non-musical productions which do not require elaborate sound effects and reinforcement. A Soundcraft Series 200 mixer and Revox B77 tape recorder can be plugged-in to sockets in either the sound

control room at the rear of the dress circle or adjacent to the stage manager's desk. Musicals at the Playhouse will generally, however, utilise a hired high specification mixer at the expense of some seats at the rear of the stalls. The theatre's sound and communications rack includes a basic complement of Yamaha power amplifiers and Electro-Voice signal processing equipment. A couple of Shure SM58 microphones and six Bose 402 loudspeakers have also been supplied.

Communications systems at the Playhouse have also been custom designed and built by Glantre and are considerably more flexible and extensive than those in the majority of the West End's commercial theatres. In addition to a stage manager's desk, pluggable stage left or right, there is a Q-Comm double ring intercom system, cuelights, backstage paging with show relay, front-of-house paging, emergency telephone system and barbells. Communications amplifiers, power supplies and mounting equipment are fitted to the combined sound and communications rack located understage in a dedicated



Behind the scenes during the long re-construction of the Playhouse.



For latest catalogue and U.K. distributor list contact: Dave Winfield JIVELIGHT Ltd Greyhound House 16-18 Greyhound Rd London W6 8NX Tel 01-381 0868

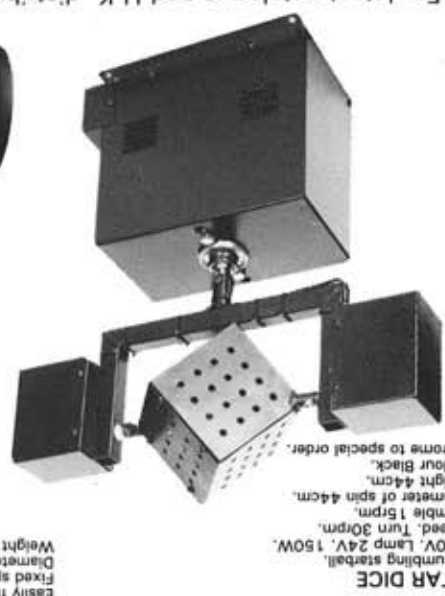

**STAR DICE**  
A tumbling starball.  
240V, Lamp 24V, 150W.  
Speed, Turn 30rpm.  
Diameter of spin 44cm.  
Turnble 15rpm.  
Height 44cm.  
Colour Black.  
Chrome to special order.



**TUBE SPOT**  
Ideal for mirror balls and for use in clusters with smoke. Comes complete with lens.  
Lamp 12V, 50W.  
Length 36cm, Width 10cm, Weight 1.80kg.



**COLOUR CHANGER**  
Easily fitted, separately wired.  
Fixed speed.  
Diameter 2.8cm, Depth 5cm.  
Weight 0.5kg.



**MINI MOON-FLOWER**  
Small, compact. Ideal for small installations and mobile use.  
Length 21.5cm, Width 17cm, Depth 10cm.  
Colour Black.  
Chrome to special order.

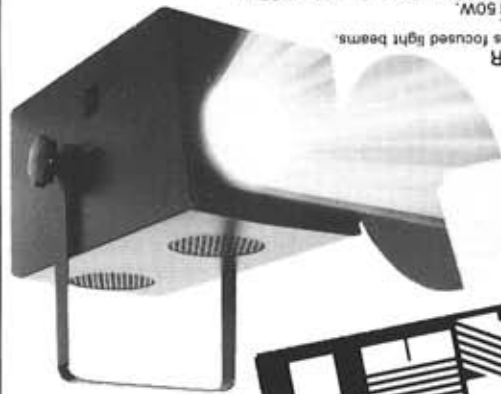

**MOON-FLOWER**  
Slowly revolving lens focused light beams.  
For use with smoke.  
240V, Lamp 24V, 150W.  
Length 43.5cm, Width 30cm, Depth 17cm.  
Colour Black. Chrome to special order.

# MINI LIGHT BEAMS FROM JIVELIGHT

sound equipment room where space is available for hired racks and for storage. Quite apart from the specialised stage systems as described, the Playhouse's electrical installations include more than 850 general and emergency lighting fittings of more than 50 different types ranging from carefully restored chandeliers and decorative fittings in public areas to modern energy-efficient luminaires in the working areas. Power supply distribution provides for temporary production stage machinery and lighting requirements as well as handling the large loads required by a fully air-conditioned theatre. Although the Playhouse has opened with temporary LEB supplies, a new 750KVA transformer substation will shortly be installed in the switchroom at basement level.

London is fortunate to regain one of its 'lost' theatres - particularly one of such architectural merit and character. Certainly no trouble and expense have been spared in restoring the auditorium to its splendid 1907 design as well as providing up-to-date and functional theatre systems and building services installations. Robin Goshaw and his team are to be congratulated on their vision, patience and determination in carrying such a demanding project through to a successful conclusion.

**Derek Gilbert** is a Chartered Electrical Engineer, a Fellow of the Institute of Electrical Engineers and managing director of Clantre Engineering Limited, of which he was a co-founder in 1974. Prior to that he spent five years each with Strand Electric and with the Thom Theatre Lighting Division. The Playhouse is one of Clantre's first significant UK projects after 12 years carrying out major overseas theatre and industrial contracts.



## GLANTRE AT THE PLAYHOUSE THE COMPLETE ELECTRICAL PACKAGE

- Strand Gemini stage lighting control, Permus dimmers, production lighting, socket box and wiring
  - installation together with working light system
  - Sound reinforcement system to basic specification together with an extensive wiring and sound box infrastructure to accommodate hired production sound rigs
  - Communications facilities including stage manager's desk, ring intercom, FOH and backstage paging, show relay and cue/light system
  - Complete electrical services installation main switchgear, power distribution, general lighting, emergency lighting, exterior floodlighting, mechanical services power supplies, telephone and fire alarm system
- For your theatre electrical and stage equipment requirements contact

### GLANTRE ENGINEERING LTD

One Royal Exchange Square  
Valpy Street, Reading RG1 1GE  
Berkshire

Telephone: (0734) 509711



The Electrical Contractors' Association





# CELCO.

~~~~~

## SERIES 2

## GOLD

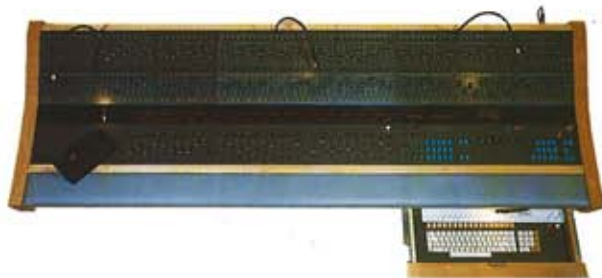

*look beyond the future*

The Series 2 Range of lighting control systems are designed and manufactured by Celco Ltd. For further information please contact our distributors. **Worldwide Distribution** Cerebrum Lighting Ltd, 168 Chiltern Drive, Surbiton, Surrey KT5 8LS *tel* (01) 390-0051/4841 *fax* 892337 **Celco G US Distribution** Celco Inc, 30 B Banfil Plaza North, Farmingdale, New York 11735 *tel* (516) 249-3662 *dialcom* IMC 1286 **West Coast Sales Office** TMB Associates, 3416 West Burbank Blvd, Burbank, California 91505 *tel* (818) 842-9652 *fax* 4900007659 TMB-UI *dialcom* IMC 2141 **Canada** Ontario, Christie Lits Ltd *tel* (416) 928-8985, Quebec, Performance Lighting Ltd *tel* (514) 526-7721 *fax* 05562232 **England** A C Lighting Ltd *tel* (0494) 39076, Ancient Lights *tel* (0953) 452210 **Finland** MS Auditron *tel* (0) 5664644 *fax* 125778 **France** Pulsar (France) S A R L *tel* (31) 741001 **Germany** Amptown Lichttechnik GmbH *tel* (40) 64600440 *fax* 94577 **Hong Kong and China** New Sounds Studio *tel* (3) 313820 **Italy** Arri Italia S R L *tel* (6) 7970797 *fax* 620339 **Japan** H Ito & Company Ltd *tel* (3) 667-3269 *fax* 2523827 **Spain** Sadepra S A *tel* (1) 246-1594 *fax* 43602 **Switzerland** PowerLight Handels A G *tel* (061) 728228 *fax* 964782 SHOWCH *fax* 061 728338

---

# AVITEC SPEAKER MENU

# AVITEC SPEAKER MENU

A small selection from the increasing range of loudspeaker cabinets offered by Avitec. With the vast plethora of sound equipment on the market today, choosing suitable components for a particular application can be bewildering. With Avitec's help this choice need not be bewildering! Avitec's menu of sound equipment is already first class with each unit selected for its particular forte in a given application. This combines with the Avitec's sales and technical knowledge and expertise of team, to make a powerfully sound reason to look closely at the Avitec sound menu before purchasing a system.

If you can't visit us, let us know your exact requirements for 'sound' advice from Avitec.

# AVITEC

THE ATMOSPHERE CREATORS

**AVITEC Electronics (UK) Limited,**  
80/81 Walsworth Road, Hitchin, Herts SG4 9SX.  
Tel: Hitchin (0462) 58961. Tlx: 825682 AVITEC G. Fax: (0462) 31019  
AVITEC & SONDOCK, Kohn 30, W. Germany, AVITEC BV, Tilburg, Holland.  
AVITECH AG, Niedergösgen, Switzerland.  
The Avitec Group - Europe's largest club lighting and sound equipment distributor.

Making a sound impression in entertainment!

# Dynacord

# RAMSA

Dynacord's new speaker range includes the **CL 820** folded bass horn and the **CL 812** compact cabinet, which can be used as a stand-alone full range cabinet or actively combined with **CL 820** as a mid/high cabinet. The new range features a new textured white finish, and incorporates a slide rail mounting system for flying. A three year guarantee reflects the manufacturer's confidence in their product. We ourselves are impressed with the tight bass and smooth reproduction through the vocal range together with crisp highs, without fatigue even at high SPLs, of the **820/812** combination. **CL 812:** 2 way (30 cm cone driver plus bi-exponential tweeter) fully overload protected. 150W RMS, 8 ohms nominal impedance, 98 dB/1w/1m, Max 123dB/1m. (W) 501 x (H) 396 x (D) 335 mm.  
**CL 820:** "Half-W" folded bass horn (45 cm bass driver) fully overload protected. 200W RMS, 8 ohms nominal impedance, 104 dB/1w/1m, Max 129dB/1m. (W) 776 x (H) 505 x (D) 425.

RAMSA's speaker range is now distributed by Avitec, with the **WS-A250** bass cabinet and the **WS-A200 E** compact cabinet bi-amped actively, being another high quality system recommended for the small to medium size club. Again, the quality is excellent, with a slightly lower bass extension (but perhaps less ultimate "punch") and a brighter top end, when compared with the Dynacord system.  
The **WS-A200 E** can be used horizontally or vertically, with both the horn and the grille being user changeable to either mode. Hank bushes are provided for flying, also in either mode. The **WS-A250** is fitted with Flanges for safe stacking where required.  
**WS-A200 E:** 2 way (30 cm cone driver plus twin Bessel constant directivity 60°H x 40°V high frequency horn) - all components thermally overload protected. 150W RMS, 8 ohms nominal impedance, 98dB/1w/1m. (W) 395 x (H) 557 x (D) 273.  
**WS-A250:** Ported bass reflex (45 cm bass driver), 200W RMS, 8 ohms nominal impedance, 100 dB/1w/1m. (W) 560 x (H) 750 x (D) 450 mm.



WS-A200E Compact Cabinet



WS-A250 Bass Cabinet

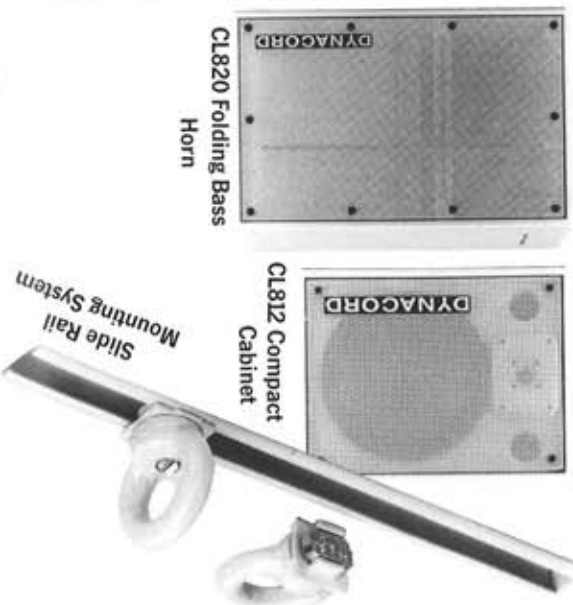

CL820 Folding Bass Horn

CL812 Compact Cabinet

Slide Rail Mounting System



# Stompin' at the Savoy

Graham Walne describes some of his experiences during five years as lighting designer to the Opera Company of Boston.

Boston Opera House began its life in 1927 as the Savoy Theatre, a cine variety house managed by the young Joseph Kennedy, father of the President. When the building was acquired, it left the Opera Company with an awkward legacy: a stage only 25 feet deep and a tiny orchestra pit. Today the theatre has a 15 foot apron and a much larger pit, but elsewhere the building is unchanged, and the proportions and lines hint at the elegance of a never to return era.

The acoustics are surprisingly good, considering the building was never intended to house opera, although they are frequently helped with gentle and skilful reinforcement from Gary Harris - who appears to conceal microphones, loudspeakers and mixing desks when we have all long gone home.

Any story about Boston Opera would be incomplete without introducing its mentor, Sarah Caldwell - officially its creator, director and conductor. A puckish and seductive genius, she is blessed with disarming wit and devastating sarcasm. She inspires loyalty and

deserves the affection she receives. Her stature (she has graced both the cover of 'Time' magazine and American Express commercials, and is one of the United States' foremost conductors) is such that her productions are devoid of personal indulgences, a rare and unfashionable approach to opera today and one which Boston frequently misunderstands. However, in Caldwell's Opera House, one can enjoy Puccini's Puccini, or Mozart's Mozart and not someone's 'interpretation'.

As a direct consequence of this artistic honesty, discussions between Caldwell and her creative team are brief because the music is always there for reference. On these occasions Caldwell radiates stimuli rather than mere directions. In discussing with me the lighting of 'Madame Butterfly', she told me that it was largely Belasco's lighting of the original play that had stimulated Puccini to create the opera. How about that for a challenge!

In Boston I had to learn to let go of a cer-

tain amount of my usual approach in order to open my mind to Sarah's improvisation, but ultimately I also learnt that this did not prove fatal. I have to say that I don't always remember this!

All sets are available on stage two weeks prior to opening and Sarah blocks and rehearses in them on stage and not in a conventional rehearsal room. I arrive 10 days before opening, and once the instruments are focused, I sit at the production desk with the memory lighting control and balance lights and write cues as I wish, by freely responding to what is happening during rehearsal. As a result, formal plotting sessions are superfluous.

This is one of the ways I have been successful in halving the lighting costs, something I believe is vital in a company so dependent on donations. Other savings have resulted from cutting the size of the rig from an average of 300 instruments to an average of 150 per production. Since most of

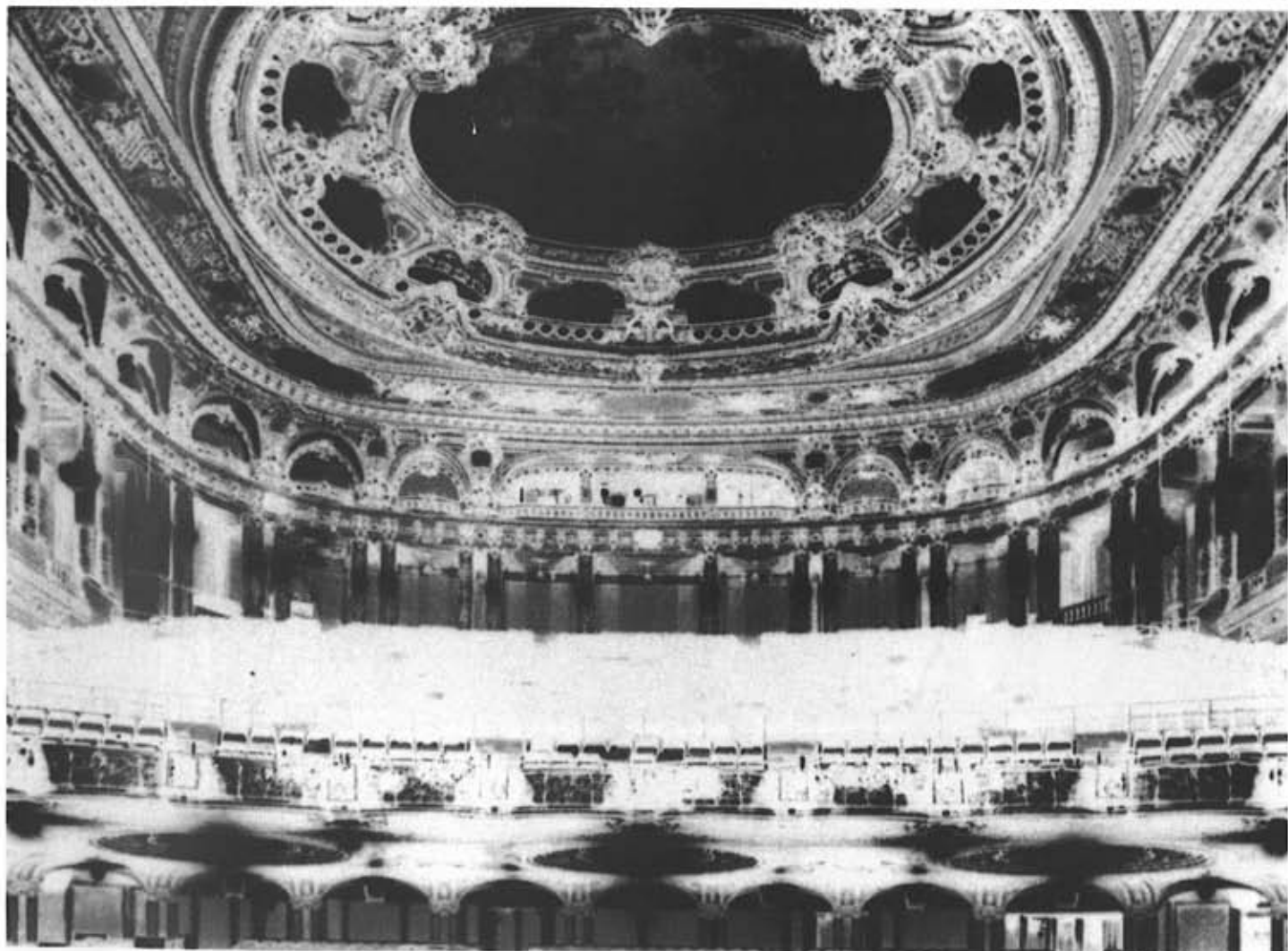



in multi-core. Whilst this could, and did until Jim Deever arrived, prove unreliable, it can also offer great flexibility. During my tenure, Jim and I have been able to reflect the changes on American practice by increasing the number of dimmer channels, simultaneously reducing dimmer capacity in addition to ceasing re-patching, an unreliable method of working I feel. Hence in six years we have moved from a five pre-set manual desk with 60 8kw channels to a Kleigl Per-former 2 with 124 channels of which the majority are 2kw and a small and variable number are 8kw for cyc lighting. After sixteen productions, Boston isn't foreign soil anymore, and this is due to the

against black velour or white sopranos in white silk against white scenery. Unfortunately the best shot, the main number one lighting bridge, is 20' upstage and therefore useless for this purpose. As a result the problems are usually overcome by high side shots from booms in the box positions. Another regular problem is overcoming the wear and tear on scenery which is brought back into the repertoire after a long absence. Drops in particular need great care and soft focused gobos, and diffusion media are good friends. Like many older American regional theatres, the Opera House has no hard-wired lighting system, so all positions are run

reach the stage and do any damage! There is a case for using spots from a tighter angle in order to highlight key people who designers have a passion to dress in the same colour as the set. Hence we spend our days lighting black sopranos in black dresses



I have often found this kind of psychology necessary when a singer demands her favourite colour, but one feels that they are unsuitable for the costumes. In one recent production when this occurred we rigged whole batteries of lights in the singer's favourite colours, all of which would have killed her costume, and plotted them into the cues so that she could see them changing. But none were strong enough for light to reach the stage and do any damage! There is a case for using spots from a tighter angle in order to highlight key people who designers have a passion to dress in the same colour as the set. Hence we spend our days lighting black sopranos in black dresses

At first I tried the ROH followspot practice of diffused pin spots, but even this proved too obtusive and the 150' throw required immense skill. I have to admit that a spot is always on standby whenever a Prima Donna is in the house, and a demand for one usually means that they are nervous about the high notes or can't remember the words. On one occasion when the spot was demanded, I used it at such a low intensity that it wasn't visible from the front even though the artiste was aware she was being followed!

Opera's technical director. The reduction in the rig is achieved essentially through a change in lighting style. Previous designers relied on large groups of instruments providing colour wash or gobo cover with followspots for key artistes. My own style relies more on specific area cover and the removal of followspots (a move which brings further savings) because Sarah and I both agreed that they were too ob-trusive.

from nine to a first class one, under the sure and sympathetic eye of Jim Deever, these are rented, there is quite a saving across a full season. A smaller rig also means a smaller crew, and this has been reduced from nine to a first class one, under the sure and sympathetic eye of Jim Deever, the



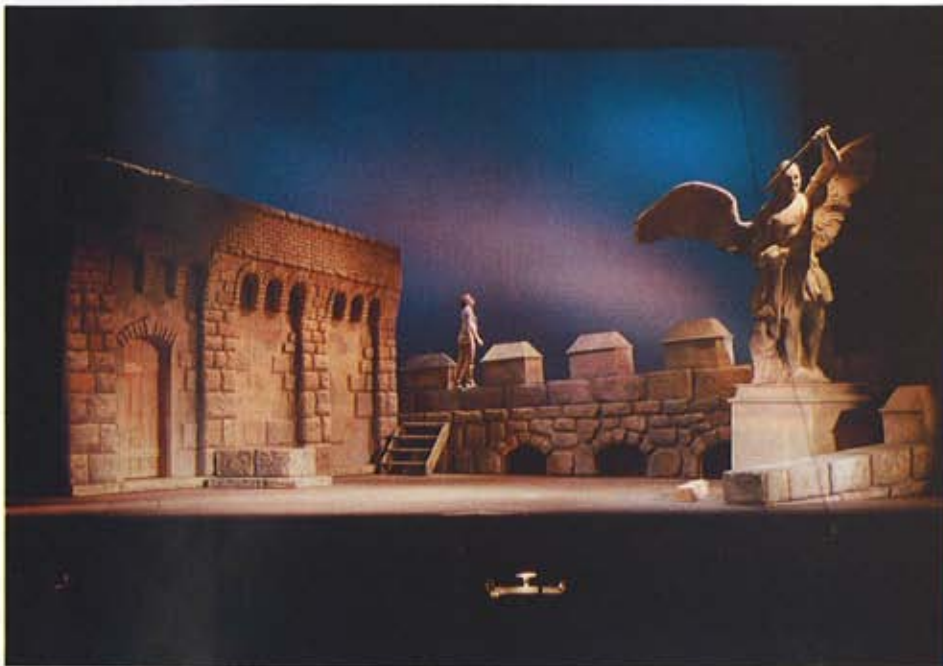

warmth of the people. The language barrier has also been overcome, and I have appended some of the more common differences here. But of course it is the music which transcends language. At any production in Boston I can find myself next to Hungarians, Israelis, and Americans as well as whites, blacks and Chinese. There are very few other fields of endeavour that people work together literally in harmony.

#### UK

bar  
house border  
safety curtain  
par battens  
luminaires  
independent  
switch on  
gobo  
cable  
splitter  
truck  
plan  
patch  
wheeled stand  
cloth  
shutters  
hood

#### USA

pipe  
grand teaser  
asbestos  
strips  
instruments  
hot patch  
make hot  
pattern  
cord  
two-fer  
wagon  
plot  
hook-up  
rolling-boom  
drop  
cuts  
top-hat



#### Adaptors - Electrical

• Beltpacks • Blood • Boom Arms • Breakaways • Blackout Iris  
• Control Cables • Chroma Key Paints • Cinefoil • Chris James Filter • Cinegel - Diffusion, Reflector and Correction • Clamps • Colorine Lamp Dip • Colour Filter • Connectors - Electrical • Colour Wheels • Control Desks • Crossbars • Dancefloor • Designer Products • Defractions • Dimmers • Display Lamps • Double-sided Tape • Extension Cables • Facet Foils • Flamex • Flameproof Materials • Flex Mirrors • Fluorescent Paint • Fog Machines • Fog Fluid • Follow Spots • Gaffer Tape • Glame • Gobos • Gobo Holders • Headsets • Hook Clamps • Iddings Paints • Iris Blackout • Lamps • Lee Filters • Loudspeaker Stations • Master Stations • Metalix • Microphones • Micro Projector Lamps • Mirror Balls • Plugs • Power Cables • Prism Filters • Profile Spotlights • Projection Screens • PVC Tape • Pyrotechnics • Rosco Colour Filters • Roscobond • Roscoglo • Roscolene • Safety Chains • Shrink Mirror • Slit Drape • Smoke Machines • Sockets • Sound Equipment • Sparklene • Spigots • Spotlights • Stands • Strobes • Studio Lamps • Supergel • Supersat Paint • Theatre Lamps • Tungsten Lamps • Video Lighting • Video Stands and Kits -and much, much more.

and for all your hire requirements

**LIGHTING  
SOUND  
AUDIO VISUAL  
OPTICAL EFFECTS  
& VIDEO**



**Head Office:**  
Queen's Theatre  
51 Shaftesbury Avenue,  
LONDON W1V 8BA  
Phone 01-439 2441

**Theatre Sound & Lighting (Services) Ltd**

# STRAND FILTERS

## RIGHT ACROSS THE SPECTRUM

Give those grey areas the light of inspiration with the ultimate product in the entertainment business today. Three ranges to suit every need.

### STRAND FILTERS CINELUX

A completely new and fully comprehensive range of 94 colours, correction filters and diffusion media all at competitive prices.

### CHROMOID

Re-launched as an expanded range of 70 high temperature colour effects filters for use where stability and durability are essential.

### CINEMOID

Ideal for low budget productions. A range of 29 reformulated safety colour filters.

Available from stock -

extensive distribution. ● 24-hour order despatch.

Supplied in rolls or as cut sheets. ●

25-sheet packs in handy 'use-again' storage containers. ●

All filters conform to stringent safety standards

BS3944: 1965 ● Switch books available on request. ●



### Strand Lighting

Strand Lighting Limited, PO Box 51, Great West Road, Brentford, Middlesex, TW8 9HR, United Kingdom

Telex: 27976 Fax: 01 568 2103

For further details **TELEPHONE: 01 560 3171**

or for instant service collect at "Strand Lighting Shop" at the address above.



# DIGITAL EFFECTS

The world's FIRST and ONLY real DIGITAL SOUND EFFECTS LIBRARY in crystal clear 3D-Sound as all effects are digitally recorded, mixed and mastered.

In ten different categories on easy-to-use compact discs . . . City, Domestic, Rural, Transport, Industry, Office, Leisure, Sports, Human, Special, plus a Cross-section Disc containing sounds from all ten categories.

Now available from

sound and lighting equipment from leading manufacturers



Theatre Sound & Lighting (Services) Ltd

67 Drury Lane, London WC2B 5SP

Phone: 01-836 7877/8 Fax: 01-836 7879



LOS ANGELES · NEW YORK · TORONTO · LONDON · PARIS  
BRAUNSCHWEIG · ROME · HONG KONG · MELBOURNE



# Training for the Future?

The Half Moon Young People's Theatre Entertainment Technician Course.



Training for technicians in the theatre is a subject currently under much discussion. What form should it take, and for how long? Should technicians receive pre-entry training. Is 'on-the-job' training better?

Chris Corner suggests that an optimum training programme for aspiring theatre technicians needs to combine something of both. Here, he describes a technician training course he has recently established in conjunction with the Half Moon Theatre in London's East End.

Entry to the theatre and entertainment industry is generally a difficult and sometimes frustrating process for the aspiring technician. Classically, a first theatre technician's job is at a junior level after a period of intermittent casual work, work experience or perhaps voluntary involvement at the same theatre or with a strong recommendation from that theatre to elsewhere.

The majority of working technicians enter the industry without any form of pre-entry training, and traditionally, the 'trainee' technician learns 'on-the-job'. Whether they are working on a casual basis or in a formal attachment, the aspiring technician helps the experienced venue technical staff while learning from them at the same time.

Furthermore, such on-the-job training is all too often unsatisfactory for the trainee. However keen and willing the trainee, lack of basic knowledge or skills will render him or her unable to provide useful working assistance in the early stages, and in the tightly scheduled world of technical theatre, there is rarely an opportunity for staff to devote time to instructing a trainee. Such time has to be found when the production period is over and the pressure is off. Quite naturally, working technicians are then reluctant to give up what might otherwise be time off to come into work and instruct trainees. This is understandable; they consider themselves to have been employed as technicians not teachers. The result is that the trainee often becomes highly proficient and experienced in sweeping, clearing out storerooms, filing away colour etc., and receives little serious training on matters relating to production.

This lack of more comprehensive instruction often results in narrow areas of experience for trainees beyond which there is little or no progress, and this can curtail a trainee's chances of finding work elsewhere - even with a good recommendation from the host theatre. Technicians now need to be able to offer a much wider range of skills to meet the demands of the growing numbers of multi-purpose entertainment centres and/or small theatres with minimal staff.

'On-the-job' training often misses out the all-important basic physical principles behind the workings of equipment that can explain optimum operation and maintenance conditions. And there is then often no understanding of the physical reasons behind safety rules. Apparently arbitrary rules are always far more likely to be ignored.

It is my view therefore that 'on-the-job'



First principles: Chris Corner at the Half Moon Young People's Theatre.

training from scratch for a potential technician can be a very unsatisfactory process. And I think most technicians who received their training in this way would probably agree. Clearly, there is a need for some form of pre-entry training.

It is interesting that while there is a traditional lack of pre-entry training for technicians, there are some very good courses. From experience of working with trainees from such courses when out on attachment, it is clear that the grounding in the basics of technical theory and practice provided enabled them to achieve much better secondments. They were able to be more immediately useful to their host venues or

companies, and as a result were far more seriously involved. In this way they had many more opportunities to learn, knew enough to be able to understand what the tasks in hand involved, and could ask intelligent questions of their hosts. Clearly, pre-entry training was working well for them.

However, those courses associated with drama schools are generally stage-management courses and naturally tend to be heavily orientated towards this area while the more technical courses are often rather specialised and academically orientated and generally for a year or longer. This makes them an impossible proposition for many young people.



The Half Moon Theatre, located in the East End of London.

The Half Moon Young People's Theatre runs an extensive range of theatre events, productions and workshops reaching a large number of young people in and around the Tower Hamlets area, and they have encountered many young people with minimal experience but who are keen to try and become technicians. As a result of problems at home, poor schooling and so on, they lacked qualifications or communication skills and thus the confidence to attempt entry to formal courses or to seek casual work. But they were intelligent, numerate and enthusiastic enough to have potential as technicians.

Acknowledging this need, the Half Moon Young People's Theatre launched its first Entertainment Technician Course last year with a generous grant from the Monument Trust. This two-part, full-time course consisted of eight weeks intensive instruction followed by an eight week period of attachment to a professional theatre or entertainment venue.

The instruction period was designed to provide each trainee with a broad basic set of practical skills and knowledge that would enable them to be of immediate practical use to the host venue from day one of the attachment. The host venue would then receive a genuinely useful technical assistant who could be given meaningful operational and production roles, enhancing the attachment for the trainee and combining the best aspects of 'on-the-job' and pre-entry training.

The course covered the basic principles of the working, setting-up, maintenance and operation of lighting equipment; the function, set-up and operation of sound equipment; simple projection; pyrotechnics; lighting equipment and techniques and lasers. A section on basic lighting design practice was also included. This was not intended to teach trainees to be lighting designers as such but to help them appreciate the overall process so that they might make better technicians.

During the teaching period, the emphasis was always firmly on the acquisition of practical and operational skills. Informal lectures were accompanied by regular demonstrations of the equipment/effect etc. involved.

Using the information and experience gained, and with further generous funding from the Monument Trust, we intend to build on the success of this pilot course and put into effect a three year expansion and development programme, and the first stage of this is the second course which began in October.

The project has amply demonstrated the feasibility and apparent effectiveness of a training course of this type. The combination of a short, intensive and practical teaching period leading into serious 'on-the-job' training in an enhanced attachment has produced a training formula that seemed to work very well.

We like to think it has great potential for the future.

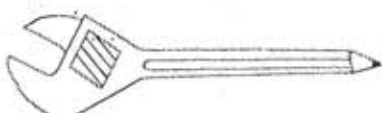

Chis Corner, a partner in Technical Theatre-Ser-

ices, is on part-time secondment to the Half Moon Young People's Theatre to devise and convene the course. (Course places are limited to young people living in the Tower Hamlets area.)

Following its completion, seven of the ten pilot technical course students were soon in employment.

This pilot course aimed to train its students seriously while also researching the logistical and financial needs, optimum course content and exploring instruction methods. It was very successful in achieving both its main aims. Of its ten students, seven were soon in employment after the end of the course, (two returned to full-time education; and one has recently had a child.) And one of our star pupils was offered a job at the National Theatre!

Using the information and experience gained, and with further generous funding from the Monument Trust, we intend to build on the success of this pilot course and put into effect a three year expansion and development programme, and the first stage of this is the second course which began in October.

The project has amply demonstrated the feasibility and apparent effectiveness of a training course of this type. The combination of a short, intensive and practical teaching period leading into serious 'on-the-job' training in an enhanced attachment has produced a training formula that seemed to work very well.

We like to think it has great potential for the future.

Following its completion, seven of the ten pilot technical course students were soon in employment.



#### WORLDWIDE AGENTS

AUSTRALIA: A.T. AUDIO CONTROLS PTY LTD

MELBOURNE (03) 379-1511

AUSTRIA: AUDIOSALES

MODLING (236) 26123

BELGIUM: T.E.M.

DILBEK (02) 569-1823

CANADA: OMNIMEDIA CORP.

MONTREAL (514) 636-9971

DENMARK: PER MEISTRUP PRODUCTIONS

KARLSJUNDE (02) 151300

FINLAND: MS AUDIOTRON

LATTIANTTI (90) 566-4644

FRANCE: REGISCENE

PARIS (01) 4396-5050

GREECE: ALPHA SOUND

ATHENS (01) 363-8317

HOLLAND: AMPCO

MAARSSSENBROEK (30) 433134

HONG KONG/CHINA: TOM LEE MUSIC CO

HONG KONG (3) 722-1098

INDONESIA: PT AUVINDO MERIEN PRIMA

JAKARTA (01) 323029

ISRAEL: BARKAI

RAMAT-GAN (03) 735178

ITALY: AUDIO LINK

PARMA (0521) 598723/4

JAPAN: EGGTECH (JAPAN) LTD

TOKYO (03) 295-4731

KOREA: YUNG NAK SO RI SA CO

SEOUL (01) 267-9697

NORWAY: NORDTEK EQUIPMENT

OSLO (02) 231390

SINGAPORE/MAIATIA: SWEET LEE

SINGAPORE (03) 336-2307

PORTUGAL: CASA CAIUS ARTIGOS MUSICAIS LTD

OPORTO (02) 0384456

SPAIN: LEXON

BARCELONA (03) 203-4804

SWEDEN: SOUNDTECH

TULLINGE (08) 778 1177

SWITZERLAND: SINEC

SCHONENWERD (64) 413747

TAHITI: MUSIC SHOP

PAPEETE (689) 428-563

THAILAND: BANGKOK CINE/GRAPHIC CENTRE

BANGKOK (02) 314-3570

K.C.M. BANGKOK (02) 222-4712

TURKEY: NEFAN

ISTANBUL (01) 160-4514

U.K.: TURBOSOUND LTD

LONDON (01) 226-0099

U.S.A.: TURBOSOUND, INC

NEW YORK (212) 460-9940

WEST GERMANY: ADAM HALL

USINGEN (6081) 16031

UK DISTRIBUTORS:

SOUTH-EAST: BODLEY KNOSB LTD, UNIT 2,

THE PINES TRADING ESTATE, BROAD STREET,

GUILDFORD GU3 3BH, TEL: (0483) 504868.

CONTACT: SIMON CURRY

SOUTH-WEST: DRV, THE MAWES,

LOWER TREGENVA, ST. COLUHA MINOR,

NR. NEWQUAN, CORNWALL, TR8 4HS.

TEL: (0637) 875824, CONTACT: ROGER VINTON.

LONDON: ELECTROMUSIC, 89-97 ST. JOHN STREET,

NORTH: THE MUSIC COMPANY, UNIT K,

HAILAM ROAD INDUSTRIAL ESTATE,

CANAL ROAD, BRADFORD, TEL: (0274) 370966.

CONTACT: PAUL SMITH

SCOTLAND: THE WAREHOUSE, UNIT 14,

50 WEST HARBOUR ROAD, EDINBURGH, EH5 1PU,

TEL: (031) 552 8194, CONTACT: NEIL HUTTON.



# INSTALL A TURBOSOUND SYSTEM AND WE'LL GUARANTEE YOU A WIDER AUDIENCE.



If your venue's sound system is restricting your options, rest assured you're in good company.

Thousands of 'house systems' have been installed over the years. But few are capable of doing justice to today's breadth of material.

So if attracting a wider audience is your objective, we suggest you join the enlightened venues that are changing to Turbosound.

Because among conventional house systems, ours comes like a bolt from the blue.

A combination of low distortion, tightly controlled dispersion and high efficiency means it's as dynamic at disco as it is confident with conferences.

Unique Turbosound loading principles help convey the clarity and vocal performance of a top quality hi-fi system.

With the controlled power to project right into your venue's farthest corners. Directing front-row sound quality to every seat in the house. The benefits don't end there though.

Our 'natural technology' enclosures (almost every component of which we design and build ourselves) require no

'black box' electronics, no external trickery, to produce their optimum performance.

So as well as being straightforward to operate, their inherent reliability means faultless operation year after year.

As you're probably beginning to appreciate, this is no ordinary sound system.

Installations from the Grand Ole Opry in Nashville to Blackpool Winter Gardens, from the Sydney Entertainment Centre to the Portsmouth Guildhall, testify to that.

To give your ears a chance to judge for themselves, call one of the official distributors listed or our Head Office, to arrange a personal demonstration and details of our comprehensive installation service.

We guarantee you'll reach a wider audience than you'd ever thought possible.

 **Turbosound**   
ONCE HEARD NEVER FORGOTTEN

TURBOSOUND LTD., 202-208 NEW NORTH RD., LONDON N1 7BL. TEL: (01) 226 0099. TLX: 265612.  
FAX: (01) 354 4940. IMC: TURBO-UK. TURBOSOUND INC., 611 BROADWAY, NEW YORK, NEW YORK 10012.  
TEL: (212) 460 9940. TLX: 230889. FAX: (212) 460 9947. IMC: TURBO-US.



# "The Sound of the Future"

Cerwin Vega loudspeakers are well known for their astounding bass output, as epitomised by the legendary L36-JE "Junior Earthquake" folded horn bass cabinet. The NEW version of this cabinet is shown right, and a group of two, or a quad array in a larger venue, will produce powerful, exciting bass down to 32Hz.



**L36-JE** ▶

Recent new exciting developments in technology from Cerwin Vega have resulted in a new range of mid/high and full range cabinets that are easily up to the high standards of their bass cabinets. The flagship of this new range is CV's ultimate mid/high system, the Dual Spruce Moose DSM-200, which is a two way all horn loaded cabinet, giving advantages in efficiency, low distortion, pattern control and transient response. CV's unique 90° bent horn design allows nearly a metre of path length in a compact cabinet only 432mm deep! A newly developed M-162 midrange high sensitivity compression driver replaces "power hungry" cone drivers with none of the disadvantages formerly associated with mid compression drivers i.e. "boxy" coloured sound, lower frequency response non linear in the DSM-200, twin M-162 units drive through the midrange 90° H x 40° V Constant Coverage horn to give a phenomenal 111dB 1w/1m sensitivity with a maximum of 134dB/1m! The frequency response is virtually flat down to 200Hz, enabling a perfect match with all Cerwin Vega bass cabinets, and voice fundamentals and harmonics are seamlessly reproduced over a single bandpass without crossovers, and with exceptionally low distortion. This provides stunning realistic vocal reproduction, virtually unpassed by competing systems at any price!

High frequencies above 3.5kHz are reproduced by a new CV titanium compression driver and a 90° x 40° Constant Coverage horn through an inbuilt passive crossover, with unconditional protection provided by an inbuilt self resetting circuit breaker. The extremely high output level of the DSM-200 means that two units can cover a relatively large venue, with none of the phase cancellations and diffuse sound that can be caused by multiple speaker installations, and the precise and constant pattern control eliminates spillover and hot and dead spots and also minimises sound reflection problems in venues with problematical acoustic characteristics.

## DSM-200 "Dual Spruce Moose"

Another NEW high output, long throw mid/high cabinet from Cerwin Vega is the all horn loaded D32-C cabinet, utilising two front baffle loaded 30cm cone drivers, one midrange compression driver and constant coverage 60° H x 40° V horn, and one high frequency compression driver and horn in a system complete with all necessary passive high level crossovers.

Further information on all Cerwin Vega products is available on request

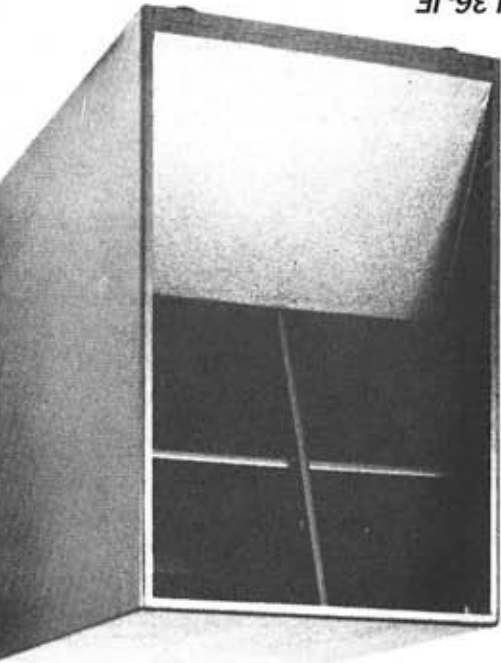

**L36-JE**

Power handling: 400 watt.  
SPL: 104dB 1w/1m,  
129dB/1m at rated input.  
Dims (HxWxD): 915 x 610 x 915mm.  
Frequency response: 32Hz-300Hz.

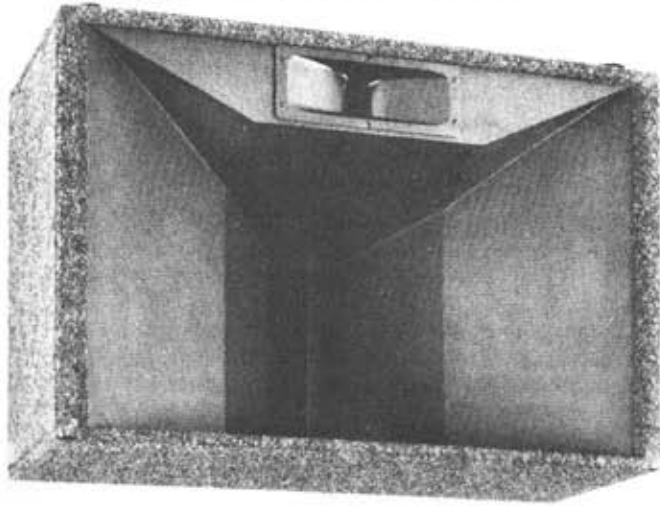

**DSM-200 "Dual Spruce Moose"**

Power handling: 300 watts,  
SPL 111dB 1w/1m,  
134dB/1m at rated input.  
Frequency response: 200Hz-20kHz.  
Dims (HxWxD): 610 x 915 x 432mm

# Cerwin-Vega... AVITEC

THE ATMOSPHERE CREATORS

AVITEC Electronics (UK) Ltd., 80/81 Walsworth Rd, Hitchin, Herts SG4 9SX, England. Tel: Hitchin (0462) 58961. Tlx: 825682 AVITEC G

AVITEC — making a sound impression in entertainment



# Midnight's Variety

Roger St. Pierre talks to Mike Townsend and David Bryant at Midnight Design.

If variety is the spice of life, no wonder that the people at Midnight Design seem so happy. To quote 27 year old Mike Townsend, who set the business up less than a year ago with 26 year old partner David Bryant: "Every job we do seems to be totally different from the last one."

Old school friends, Mike and David were not clear exactly what they wanted to do when they started their company, except to work together. "Midnight Design has evolved in its own natural way rather than being planned," says Mike. And that means taking on all sorts of commissions - the more bizarre the better.

How about the staging of a lavish £150,000 society wedding, in Brixton, of all places, or the setting up of a temporary state-of-the-art discotheque aboard a train? Those are just two of the jobs to come the way of a company which specialises in the unusual: "We are into designing and installing permanent lighting rigs in clubs and so on, but we get most fun out of providing the lighting for one-off events, whether it's something like a disco night at a swimming baths or a major product launch."

Mike and David went to school together in Bromley and ran a mobile discotheque as partners between 1974 and 1976, at the start

of the punk movement. "We then went our separate ways, with David moving down to Bristol for some time," explained Mike. "I trained in electronics development - in fact, I sometimes feel I should be designing computers now! I worked as lighting engineer at Richard Branson's 'The Venue' for the last six months of its existence, and from that came close links with the Virgin group which have lasted till this day. We still stage many of their major events."

"I fell out of Mirage Lighting before it all went wrong and then went freelance for Entec before setting up a partnership with David a year ago. After six months or so we decided to do it properly, rather than remain a garage company, and now we have expanded to a stage where we employ seven people and have large premises on two floors of an old warehouse near Olympia." David's background lays in theatre. He started in stage management and then became a prop maker, which led him into technical props and special effects, like exploding furniture. His work on 'Where The Wind Blows', which opened in Bristol and then moved up to London, involved the staging of a simulated nuclear explosion.

John Williams was the lighting designer for that one and he got David a job as lighting designer at the Bristol Vic. But being evicted from his flat prompted him to move back up to London. He recalls: "I got in touch with Mike. He had a lot of lighting experience and was from a rock 'n' roll background while I knew theatre and had lots of design experience. We had no money, so the original thought was to work as consultants, using other people's gear."

As a follow-on from his work at The Venue, Mike had become involved in servicing the lighting at other Virgin clubs, and just as Dave joined him he received a commission from Virgin to install a new lighting system and external lighting at the Roof Garden in Kensington.

"Starting out, we took any work we could get," Mike remembers. "Gradually we built up our own stock of gear which we were able to hire out on various projects. For instance, the lighting system we installed at John Gunnell's Astoria is actually owned and maintained by us."

"We have expanded cautiously, almost in fits and starts. We've been careful to avoid the usual syndrome of rapid expansion followed by sudden disappearance. It is so easy to over-reach your resources in this business. Running a company can be a real nightmare, especially when what you really want to be doing is not sorting out the cash-flow and running the books but going out there and running the shows."

"Our work for Virgin provided a solid base for Midnight Design and we also found ourselves called in as sub-contractors on other peoples' jobs. We spotted gaps - like providing strobes - so we built up a lot of hire stock and this investment in gear really opened up the market for us."

"We like to do the unusual, the bizarre,



Midnight Design's David Bryant (left) and David Rose.

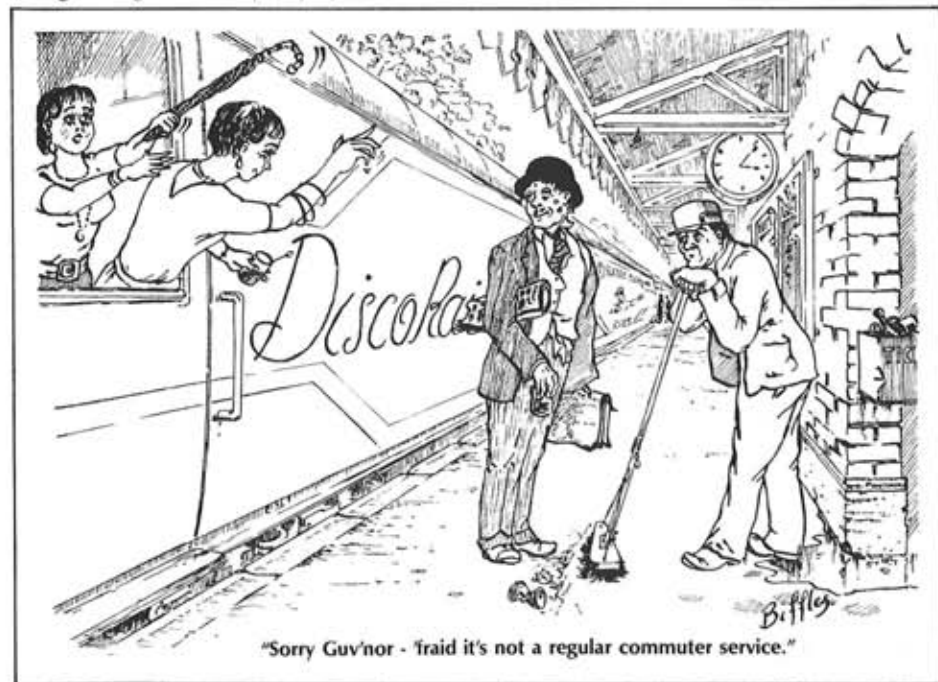



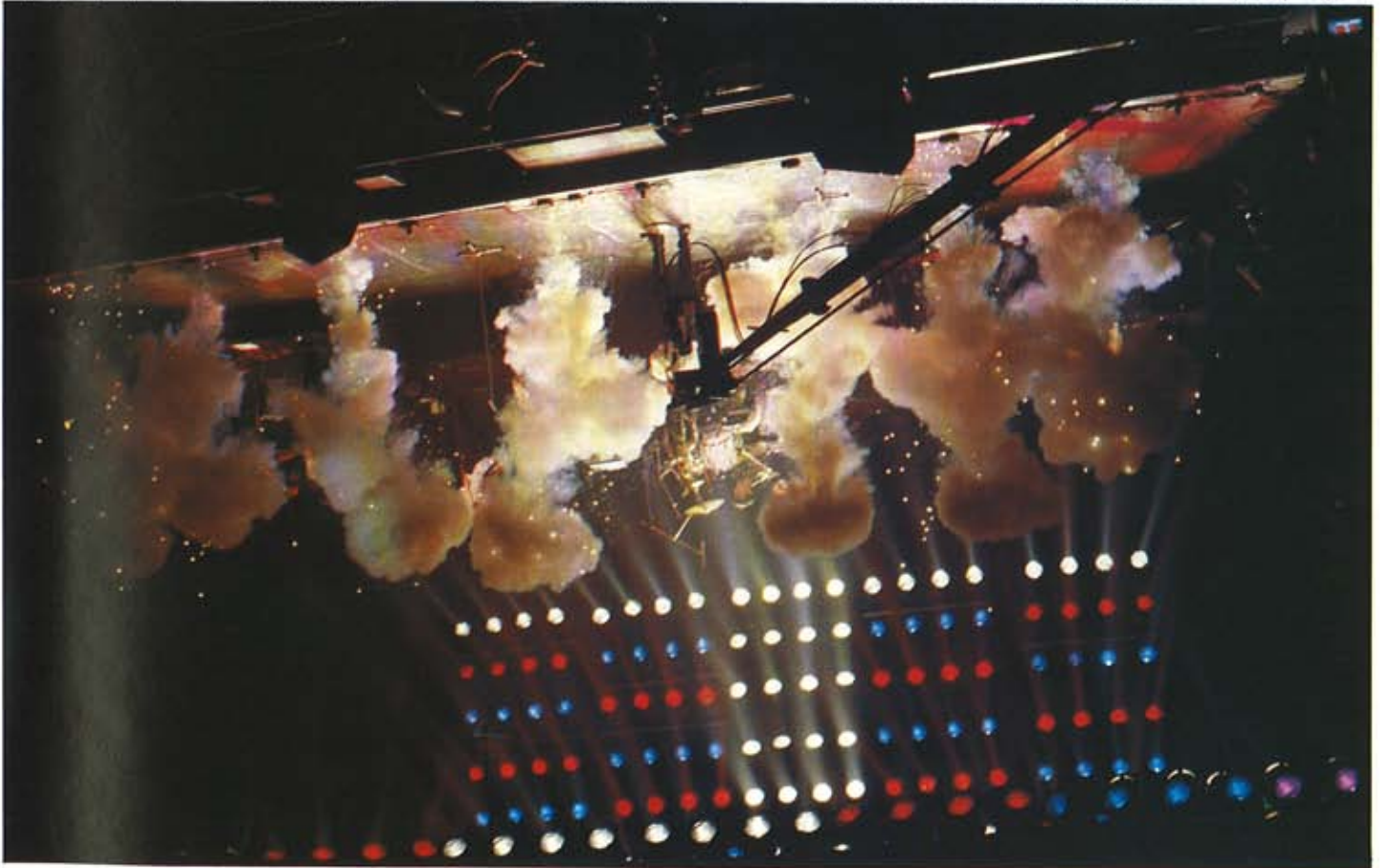

Another shot of a recent video take at London's Astoria Theatre - see also page 5. The lighting rig at the venue is Midnight design owned and maintained.

and we get a lot of outdoor work. For instance, we provided the lighting for a Cleo Laine outdoor concert at Tilbury Fort in Essex. The wedding at Brixton Academy really gave us a chance to let our imaginations run wild. It was a fabulous event. We turned the place into an illuminated park, with a gazebo on stage. £45,000 went on flowers and £60,000 on trees. There were 450 guests and the whole affair was a stunning success." National press headlines were won for Midnight Design when they staged the lighting for the Militant Tendency Rally at the Royal Albert Hall: "It was that event which really introduced the razzamatazz of American politics to the British scene, paving the way for the Tories and the Labour Party to put on truly staged events."

"We put on a synchronised laser display and a mist of white smoke as Derek Hutton, Tony Mulhearn and Peter Taffe came out on stage, and their images were thrown on to a 40 feet screen. The atmosphere was electric. "Putting that event together was a tremendous challenge. We treated Militant as we would any other client - you don't have to agree with their politics to do work for them."

Midnight Design have also been doing a lot of night club work, especially providing the lighting for special evenings: "Really it is an extension of the old warehouse party idea. People take a club over for the night and want it transformed. We put on the Deletem weekly disco parties at the Astoria. They were fantastic events lasting eight hours or more and featuring such things as BMX riders, mud wrestlers, four or five bands playing live, top D.J.'s, videos and so on - unreal," said Dave.

"At the Academy we have been doing the Westworld events which attract 7,000 people and include such things as fairground rides as part of the disco entertainment. Another good commission was Richard Branson's party. At first we were asked just to do



The set for the ERMA conference at the Nice Acropolis Convention Centre.



The wedding at Brixton Academy - "we turned the place into an illuminated park."



the lighting but we ended up staging the whole event. As a result, we are now getting a lot of conference work. We've been out on jobs with Spectrum, as part of their crew, and we supply lighting equipment to other people too while, in our own right, we are now getting quite a bit of corporate work. For instance, Dave designed the European Federation of Monetary Associations Conference.

"The train commission was one of the most fun things for us. It was for a guy called James Goodyear who runs it as 'The Train Set', aiming at the yuppie set and all those people with allowances from daddy. Apparently, James got the idea during a train journey in Yugoslavia when someone produced a ghetto blaster and an impromptu party started. He thought: 'Oh this is a good idea.'

"James hired the rolling stock from a company which leases it out for exhibitions, and things like the Radio One Roadshow. Now he is looking to buy his own carriages. The whole thing was a great success. The train went from Waterloo to Southampton and back and was then shunted over to Victoria and went from there to Brighton and back.

"Coming up with a suitable lighting system was quite a challenge. You don't realise what an odd shape a railway carriage is until you take all the seats out! We had to work with a space which was 76 feet long but just 7ft 6in wide and with a height ranging from 6ft 6in to 7ft 6in at the centre of the carriage. It doesn't exactly give you a lot of space to play with.

"The windows were blacked in, leaving us with a long, dark corridor. There were physical limits to what we could do, and the whole thing had to be punter-proof. There was a decided lack of space for a dimmer controller, and it all had to be shelf-mounted. We put in a Midnight Design swop-rack and switched 12 channels of 240 volts with output of from three to 33 volts operated via a Zero 88 Orion programmable controller.

"We had to work on two carriages. In the Blue Carriage, we put two Starcloths, two Terrastobes, two Solar 250 projectors with laser-style beam effect, 14 lengths of Mode Arcline, a couple of handfuls of pinspots and our own home-made mirrorballs - they are great on a train as you don't need a motor. The rocking motion keeps them turning!

"In the Pink Carriage, we had two 400 watt UV floods, two twin-head Nisel scanners, two Solar 250s with laser effect, two White Lighting strobes, 24 Par 16s and 120 egg strobes. Altogether there was some £35,000 worth of gear on that train and the effect was quite stunning."



'The Train Set' - above and below. "Coming up with a suitable lighting system was quite a challenge."



Equally adventurous was the Wetworld promotion at Hammersmith and Fulham Baths which involved creating a discotheque in a swimming pool. "That has to be one of the best fun gigs we've done in ages," enthused Mike. "It might sound unusual, but the swimming/disco mix really worked well and everyone had a great time.

"Staging events in weird places allows you to be that much more creative. We have concentrated on the lighting side of things

and we leave the sound to specialists but we are now increasingly getting involved in providing all the other props and giving people and complete package for their event so that all they have to provide is the people."

Dave chipped in: "Mike loves solving electronics problems and with my designs I like creating the problems for him to solve! Provided the client has the money to pay whatever it might cost, the sky's the limit in what we can do."



Midnight Design's trade counter in West Kensington.



Steve 'Custard' Clark (left) and Mike Townsend.

Stunts

Special Effects

Music

# Entertainment Programme Day and Night

Staging

Seating

Organised by  
 Brintex Limited  
 178-202 Great Portland Street  
 LONDON W1N 6NH  
 Tel: 01-637 2400

In association with  
 The Institute of Entertainment and Arts Management  
 Seminar/Entertainment/Delegate  
 enquiries to be directed to:  
 3a/5a Stanley Street,  
 SOUTHPORT,  
 Merseyside PR9 0BY  
 Tel: 0704 42991  
 and  
 Supported by  
 The Stage and Television Today

Phone or send for a complimentary ticket now

## Make sure you're a part of it as well!

Lighting

Displays

|           |             |                   |
|-----------|-------------|-------------------|
| Monday    | 16 November | 10.30-18.00 hours |
| Tuesday   | 17 November | 10.00-18.00 hours |
| Wednesday | 18 November | 10.00-16.00 hours |

16 - 18 NOVEMBER 1987  
 THE INTERNATIONAL  
 CONFERENCE & EXHIBITION CENTRE  
 HARROGATE



Entertainment & the Arts '87  
 EXHIBITION & CONFERENCE

## They're all at the

Venues

Ticketing Systems

Artists

Fireworks

Promoters

Agents



# SHOW PAGE *with PLASA News*

## Ton-up for PLASA

At the executive committee meeting held on October 5th no less than eleven new companies were admitted as members of PLASA, raising the total membership over the 100 mark for the first time.

102 companies are now in full membership of the Professional Lighting and Sound Association and several new membership applications are currently in the pipe-line.

What odds the membership tally will reach 150 by the time of the 1988 Show at Olympia 2?

The eleven who brought up the hundred are:

**Adam Hall Supplies Limited**  
**Exciting Lighting & Decor**  
**Harman (Audio) UK Limited**

**Hazel Grove Music Company Limited**  
**Jasco Light & Sound Limited**  
**Lighting & Sound Services**  
**Opus Amplification**  
**Roscolab Limited**  
**Stardream Audio Visual Limited**  
**Wembley Loudspeaker Co. Limited**  
**Wynne Willson Gottelier Limited**

PLASA chairman Peter Brooks told L+S: "Obviously I'm extremely pleased with the progress of the Association, and hope that the new benefits we are beginning to provide are making membership more worthwhile. It would be appreciated, of course, if members could contact the PLASA secretary Tony Andrew at the Eastbourne office with any suggestions for further services they feel PLASA should offer."

## 1988 Light & Sound Show — Booking Commences

PLASA exhibition organiser David Street has announced plans for selling space at the 1988 Show to be held at Olympia 2 from 11-14 September.

From early this month space will be made available in the first instance by order of stand size taken in 1987 to the 30 largest stands, and members will have seven days to make a deposit payment, once their selection has been made. If this is not received the stand will be made available to other members of PLASA.

From 1st December stands will be available on a first-come first-served basis to PLASA members only. Non-member companies may apply for stands from 11th January 1988 when the plans will be open to all potential exhibitors.

In an endeavour to counter the problems of sound demonstrations held on open stands at the 1987 show, demonstrations of sound equipment will only be allowed within an enclosed area, and to aid exhibitors, additional walls, doors and solid ceilings will be made available. There will also be a 'no sound' area on the first floor within which no sound equipment may be played whatsoever.

In the event of problems, if the organiser receives three separate complaints from other exhibitors, the offending company will lose the power supply to their stand.

For full details of the 1988 Light & Sound Show contact David Street, PLASA exhibition organiser, at 10 Barley Mow Passage, Chiswick, London W4 4PH telephone 01-994 6477.

## PLASA Commissions Major Research Project with City University

London's City University's Department of Arts Policy and Management has been commissioned by PLASA to conduct a survey to establish the present size and value of the industry, covering such topics as annual turnover, number of employees, and value of exports.

The full brief is yet to be worked out, but it is envisaged it will also include the rate of growth over the last five years, projected growth, and perceived movements in demand for particular types of equipment, and users and buyers of equipment.

The Department of Arts Policy and Management is based at the Barbican Centre in the City of London, and is headed by Professor John Pick. Researcher heading the project is Caroline Gardiner MA DipBEC, the senior research fellow in the Department, who has worked on numerous projects for the past seven years, in particular the major audience project for the Society of West End Theatre.

It is anticipated that the first stage of the PLASA report will be ready by March 1988.

## Exhibition Diary

### Entertainment and the Arts '87

Exhibition & Conference  
November 16-18, 1987.

**Harrogate** Conference Centre, Yorkshire.  
Organised by Brintex Limited.  
178-202 Great Portland Street,  
London W1N 6NH.  
Telephone: 01-637 2400.

**The 2nd Scottish Pub, Club, Hotel & Catering Show**  
February 23-25, 1988.

The Edinburgh Exhibition and Trade Centre, Ingliston,  
**Edinburgh.**  
Enquiries: Ian Macfarlane Exhibitions Limited,  
676 Wilmslow Road, Didsbury, Manchester M20 0DN.  
Telephone: 061-434 5300.

### Frankfurt Music Fair

March 9-13, 1988.  
Frankfurt Fair Centre, **Frankfurt**, West Germany.  
UK Representatives: Collins and Andres,  
18 Golden Square, London W1R 3AG.  
Telephone: 01-734 0543.

**FOR DETAILS OF  
ADVERTISING IN  
LIGHTING + SOUND  
INTERNATIONAL  
ring (0323) 642639**

### SIB Rimini

March 22-25, 1988.

### Rimini, Italy.

Este Autonomo Fiera Di Rimini,  
PO Box 300, 47037 Rimini, Italy.

Telephone: 0541/773553.

UK enquiries: Disco & Club Trade International.

Telephone: 01-278 3591.

### USITT Conference/Stage Expo '88

March 23-26, 1988.

### Disneyland Hotel, Anaheim, California.

Show manager: Richard James, 486 Fullerton Court

San Jose, CA 95111

Telephone: (408) 225 6736.

National office: 330 West 42 Street, Suite 1702,

New York NY 10036.

Telephone: (212) 563 5551.

### Nightclub & Bar Expo

March 28-30, 1988.

### The Bally, Las Vegas.

Show co-ordinator: Woody Farris, Nightclub & Bar.

Telephone: (601) 236 5510.

### SIEL '88

April 10-13, 1988.

### Porte de Versailles, Paris, France.

Organisation: Bernard Becker Promotion,

161 Boulevard Lefebvre, 75025 Paris.

Telephone: (14) 533 74 50.

### Pub, Club and Leisure Show

April 12-14, 1988.

### Olympia 2, London.

Angex Ltd., Europa House, St. Matthew Street,

London SW1P 2JT.

Telephone: 01-222 9341.

### ABTT Trade Show

April 14-16, 1988.

### Riverside, Hammersmith, London.

Enquiries: ABTT, 4 Great Pulteney Street, London

W1R 3DF.

Telephone: 01-434 3901.

### Expo Musica, Madrid

April 20-24, 1988.

### Madrid, Spain.

Organised by IFEMA (Institution Ferial de Madrid),

Avda de Portugal, s/n Casa de Campo,

28011 Madrid 1101.

Telephone: Madrid 470 10 14.

### Audio Visual '88

April 25-28, 1988.

### Wembley Conference Centre, London.

Enquiries: EMAP/MacLaren Exhibitions Limited, P.O.Box

138, Token House, 79-81 High Street, Croydon CR9 3SS.

Telephone: 01-688 7788.

### Showtech '88

May 18-20, 1988.

### Trade Fair Centre, Berlin.

Enquiries: German Chamber of Commerce,

12-13 Suffolk Street, London SW1.

Telephone: 01-930 7251.

### PLASA Light & Sound Show '88

September 11-14, 1988.

### Olympia 2, London.

Exhibition Organiser: David Street,

Telephone: 01-994 6477.

General Enquiries: PLASA general secretary,

Tony Andrew, 7 Highlight House, St. Leonards Road,

Eastbourne, East Sussex BN21 3UH.

Telephone: (0323) 410335.

### Photokina

October 5-11, 1988.

### Cologne, West Germany.

UK Representative: Tony Pittman,

12/13 Suffolk Street, London SW1Y 4HG.

Telephone: 01-930 7251.

### Disotec/Hogatec

November 7-11, 1988.

### Dusseldorf Messe, West Germany.

Enquiries: Miss Renata Born or Mr Peter Brodie,

Dusseldorf Trade Fair, Charles House,

108-110 Finchley Road, London NW3.

Telephone: 01-794 0166.

# THE NEW PORTAPAK 3

# ON THE ROAD RELIABILITY

The new Portapak 3 touring dimmer system is designed for life on the road. With all the capability you need, the reliability you need, the reliability you demand and the quality you'd expect from Pulsar, the dimmer professionals. When your reputation depends on it — the Portapak 3 won't let you down.

## Specification

- 36 Channels — 10 amps per channel. Each channel fitted with fuse, fuse-blown indicator and manual test switch.
- Fan fitted for every 6 channels to eliminate overheating worries.
- Mains patching — either serial for 110 volt lamps or parallel for 240V lamps. Makes it possible to pair any two lamps together onto any dimmer channel. Standard Socapex outlets.
- Signal patching — from standard 30 channel Socapex signal input or twin BICC sockets, via a banana plug patch to DIN outlets for each dimmer module.
- Camlok 3 phase mains inlets.
- Compatible with Celco and Avolites lighting boards.
- Wired, tested and ready for use.

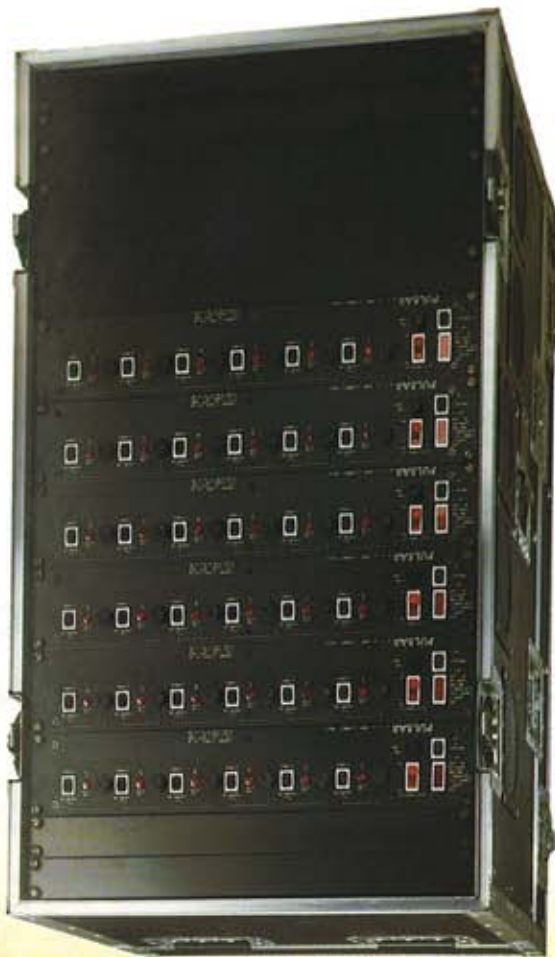

## AND THE PERFORMANCE YOU'D EXPECT FROM PULSAR

# PULSAR

**Lighting for Effect.**

Pulsar Light of Cambridge Ltd.,  
Henley Road, Cambridge CB1 3EA.  
Tel: 0223 66798 Telex 81697 PULSARG

Pulsar GmbH,  
AM Vorort 23,  
D-4630 Bochum 7, West Germany.  
Tel: 0234 28171 Telex 825593

Pulsar France Sarl,  
10 Avenue du Fresne,  
14760 Bretteville sur Odon, France.  
Tel: 31 741001 Telex 171237

A professional touring system from Pulsar, one of Europe's largest dimmer manufacturers.



# ON TOUR

Keith Dale

## Jethro Tull Rehearsals

G Stage, Pinewood Studios

Lighting Designer: Kevan Shaw

Meteorlites' Crew: Pete D'lemos and Paul Hawkes

It has been many years since I last heard a Jethro Tull record, and it came as a great surprise when I was asked to review the lighting for their forthcoming tour during rehearsals at Pinewood Studios. My first impression was that the tour was going to be a reunion, a re-formation of a band long since confined to the annals of rock history.

However, I was soon to be put straight on that by a bemused Kevan Shaw, Tull's lighting designer, who politely informed me that this could not be construed as a 'come-back' as that would have required the group to have disbanded in the first place - which they hadn't! Furthermore, Mr Shaw continued to rub salt into the wound by explaining that the band had been touring on and off over the last decade or two. Bearing this in mind, and after making a mental note to dismiss my 'underground' researchers, I decided to change the subject in an attempt to win back some credibility. I asked Kevan to explain the salient points of his design.

As can be seen from the design accompanying this interview, the lighting revolves round the use of a box truss, containing some instruments, under which are located three trusses running upstage/downstage, each truss having its own motors. All three 'up/down' trusses are therefore able to be moved at certain cues in the show, and 'run in' whenever desired.

Kevan had spent many hours pouring over the design to ensure that the cross-paired lights would always be in the right place on stage at all times, regardless of the truss positions. This is something that involves a lot of calculation, if you want to get it right, and Kevan, being the perfectionist he is, was not going to be daunted by such a challenge. Just in case there was a clash though, the side washes have been kept deliberately off the moving trusses and situated on the main box where they would always be at hand to give some cover as well as providing additional punch for the up-tempo numbers.

Suspended off the upstage section of the box truss are two screens and an applique back-drop, lit at an angle by a solitary fresnel on the floor. Kevan also pointed out that the trusses themselves are lit with Raylights inside them to emphasise the parts that are moving.

It was obvious that this was going to be a very theatrical show, by comparison with other rock concerts, and that Kevan would make great use of timing and pacing. To this end he is greatly assisted by the band (if that's the right way to put it), and Ian Anderson in particular, for whom he has the greatest respect. (Particularly when it comes down to being in the right place at the right time.)

The three followspots used are located on the

downstage truss rather than upfront in an attempt to eliminate the 'big white blob' on peoples faces - something that Kevan feels is normally associated with that position. With the spots located in the truss position it is claimed that a steep key effect can be obtained that does more than enough to establish position without 'over exposing' peoples faces. Kevan was quick to point out that he was aware of the problems associated in using the spots at such a steep angle but, unless film or video was required, the shadows under the eyes and nose of the performers on stage were of little consequence by comparison.

Unfortunately, one of the 'really interesting bits' that had been under consideration, namely the new Avolites' Gel Jet, wasn't available for the rehearsals. The Gel Jets are surely one of the smallest scroll type colour changers in existence as well as being one of the prettiest. It is intended that they will be used on the Par lights located on the side washes and on the upstage sections of the three moving trusses. This arrangement would enable Kevan to 'call up' a variety of different colours throughout the show from the same instruments.

The equipment on this tour was provided by Meteorlites and it was to be the first experience Kevan would have of using them in this capacity. Prior to this he had only worked with them on a trade show. Need it be said that he was suitably impressed by the standards set by the crew and the condition of the equipment? The production manager on this tour is one Kenny Wylie who, according to the interviewee, is 'absolutely the best production manager' he has ever worked with and consequently deserves to have that accolade

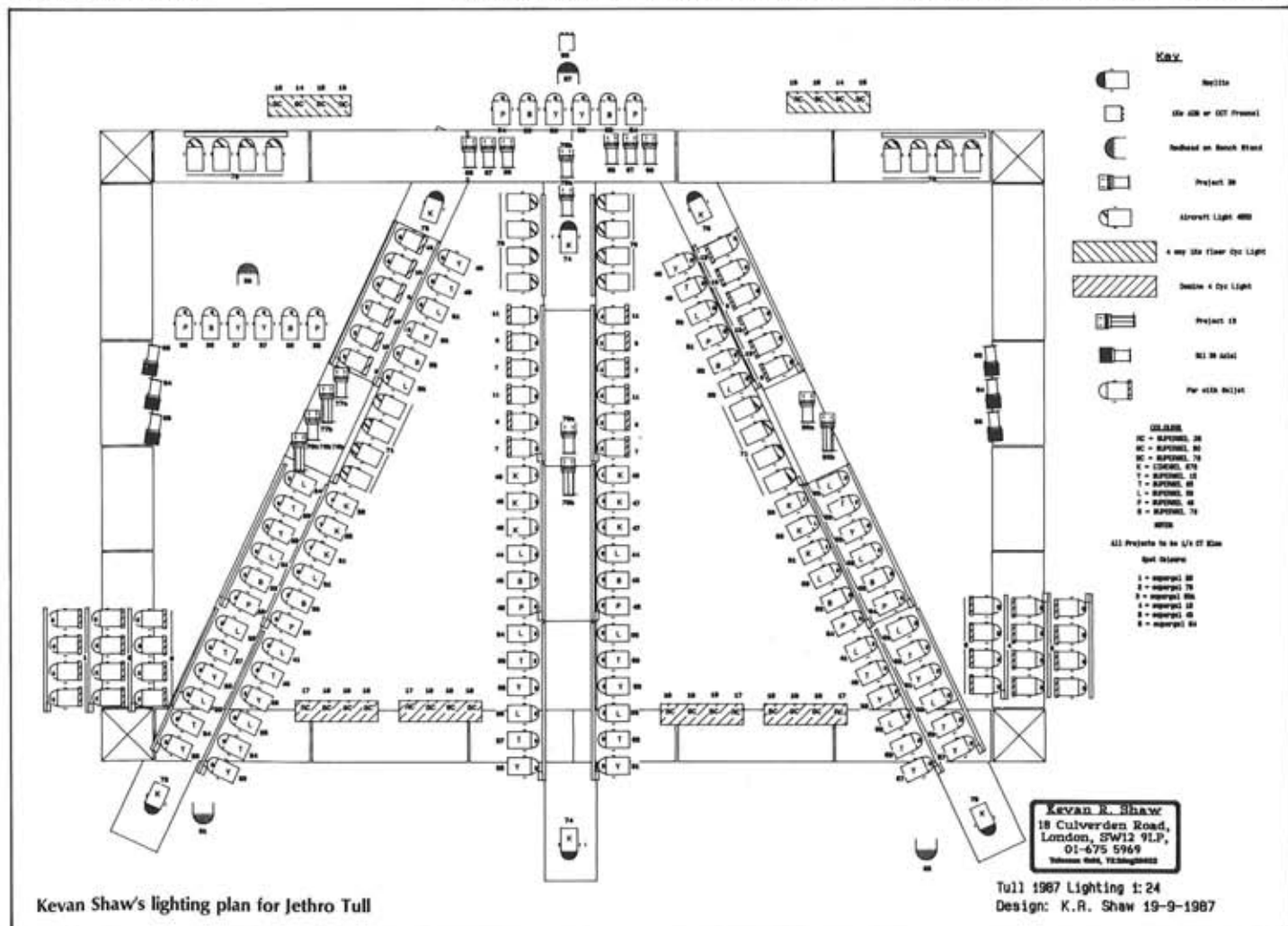

Kevan Shaw's lighting plan for Jethro Tull

fair idea of what we required. But apparently that things would be better, as we'd gone to the trouble of sending over lighting blocks to give a "We arrived in Madrid late this afternoon hoping in Spain compared to other European countries. noticed very few people appear to speak English to cue Spanish followspot operators! And I've followspots - even though it proved rather difficult. "I think it was a good show, and we had four audience wouldn't have noticed. have done was satisfy my own ego as I'm sure the programming the whole thing but all it would them as they were. I could have spent three hours form of repatching or reprogramming so I left it would take a long time to get them to do any that they were grouped together in blocks meant we were quite a lot of lights in the venue, but the way who we found couldn't speak any English! There and it took two hours just to find the lighting crew. "We arrived in Barcelona yesterday at 4.00 p.m. special performances. two Spanish dates in Madrid and Barcelona are into a European Tour supporting 'Carnet'. These with 'The Blow Monkeys', and after that we went year and then went straight into a British Tour

"I finished working with 'The Cult' in April this year and then went straight into a British Tour with 'The Blow Monkeys', and after that we went into a European Tour supporting 'Carnet'. These two Spanish dates in Madrid and Barcelona are special performances. "We arrived in Barcelona yesterday at 4.00 p.m. and it took two hours just to find the lighting crew who we found couldn't speak any English! There were quite a lot of lights in the venue, but the way that they were grouped together in blocks meant it would take a long time to get them to do any form of repatching or reprogramming so I left them as they were. I could have spent three hours programming the whole thing but all it would have done was satisfy my own ego as I'm sure the audience wouldn't have noticed. "I think it was a good show, and we had four followspots - even though it proved rather difficult to cue Spanish followspot operators! And I've noticed very few people appear to speak English in Spain compared to other European countries. "We arrived in Madrid late this afternoon hoping to give a fair idea of what we required. But apparently

Monkeys, and a few other things besides. where he talked about his work with 'The Blow recently caught up with him again in Madrid he was the lighting designer for 'The Cult', and I Earlier this year I interviewed Peter Barnes when

## The Blow Monkeys

Oh! Madrid, Madrid, Spain

Lighting Designer: Peter Barnes

The Blow Monkeys in Madrid.



has not experimented with any of the dedicated drafting software available to the lighting industry. Interestingly, the lighting design for this tour was drawn on a Macintosh, using MacDraw, and then printed out on a plotter. Using computers and their associated software in this way is becoming a fairly common practice these days, and can offer anyone with enough patience to assemble a simple database of lighting templates an accurate indication of what the design can look like in different forms without having to re-draw the entire plot. As with all C.A.D. software though, the real saving in time comes when modifications are made to an existing drawing. If you are able to get the design right first time conventional drawing practice is most probably quicker. As yet, Kevan really - only Var-Lites! And that's an argument I wasn't going to get involved in.

Having finished talking about the lighting design for this tour I asked Kevan if there was anything in particular he wanted to add. "Who was my favourite lighting designer, go on, ask me that one," was his immediate reply. So I did. And it was one Bill Duffield who unfortunately met with an untimely death while on the Kate Bush tour at Poole Arts Centre. The particularly remembers Bill Duffield for his work with Peter Gabriel which he especially when it came to spot-on cues. Was there anything Kevan didn't like? Well, not much! and Jethro Tull. Since then he has worked for many other artists and groups including Steve Hackett, XTC, and Lynx. He now spends most of his time working for D.H.A. on trade presentations and product launches.

From this developed a passion for lighting that followed through to university where she spent a lot of time on school days with various biscuit tins and 200 watt bulbs. Kevan Shaw's involvement with lighting began in his school days with various biscuits tins and 200 watt bulbs. From this developed a passion for lighting that followed through to university where she spent a lot of time on stage administration. In those days, and by that I mean the seventies, the lighting for bands was generally provided by anyone interested enough at the various colleges and universities, and it would appear that it was rare indeed for a band to carry its own equipment at that time. Kevan's first tour was with 'Love Affair', a band he first encountered at the graduation ball where he was running the lighting. From there he went, via a real job, to Showites and R.D.E. before going freelance with Ultravox and Jethro Tull. Since then he has worked for many other artists and groups including Steve Hackett, XTC, and Lynx. He now spends most of his time working for D.H.A. on trade presentations and product launches.

there was a breakdown in communication, and when we arrived there was nothing sorted out - and no followspots! "There are two ways of working these sort of places: you can treat it all in a light-hearted way and have a good time, or you can get very upset! I remember doing a Siouxie & The Banshees Tour in America when one of the venues only had three switches to operate the lights, and one of them turned on the lights in the gents toilets! It's not that bad here, although you can't do the show that you'd really like to do. "I think many people get too involved with lighting as an art form. They become too artistic and usually the management of Erasure rang up to say how much they liked it! "I hate being a sales person as I'm not very pushy, but I have to do it. If there is a new band on the road I have to chase them even though I don't like doing it, because it often means that the young person who has been lighting them while they were unsuccessful gets the push. "There are many talented lighting designers who can't get work because they have only worked with small bands. If you work for someone like David Bowie, regardless of how good the show is, you are set up for your next two or three tours. I once worked as a rigger for the lighting designer Chip Monk, and his show consisted of 100 red lights a side in a row, 100 blue lights a side in a row and 100 green lights a side in a row. For this he was being highly paid - all because he had previously worked with The Rolling Stones. "My own view was that it looked terrible."

Cañona Forcer

"My own view was that it looked terrible."

"I've also been designing for The Jesus and Mary Chain which I've found quite difficult as they openly admit that they don't like lighting! I put the side and back trusses at peculiar angles so that they appear as if they are only half assembled and that went down very well. In fact, the management of Erasure rang up to say how much they liked it!

"I hate being a sales person as I'm not very pushy, but I have to do it. If there is a new band on the road I have to chase them even though I don't like doing it, because it often means that the young person who has been lighting them while they were unsuccessful gets the push. "There are many talented lighting designers who can't get work because they have only worked with small bands. If you work for someone like David Bowie, regardless of how good the show is, you are set up for your next two or three tours. I once worked as a rigger for the lighting designer Chip Monk, and his show consisted of 100 red lights a side in a row, 100 blue lights a side in a row and 100 green lights a side in a row. For this he was being highly paid - all because he had previously worked with The Rolling Stones. "My own view was that it looked terrible."

Peter Barnes.





# THIS IS THE FUTURE



Packed with control and effects features the SP12 is a truly interactive mixer for the digital music age.

This extremely versatile instrument is intended for use by top class operators in the Disco's, A.V. production,



and commercial sound installations. The SP12 is engineered to full professional

standards, and broadcast quality audio reproduction.

## THE SP12

DIGITALLY ENHANCED

*Twin crossfades.* Enable the creative deejay to improve his performance by providing smooth, fast transition

between different channels.

### *Image Control*

This is a spectacular feature unique to the SP12 which transforms ordinary stereo originals into "Super Stereo". This has much greater



separation than ordinary stereo and gives an enhanced image.

**HARRISON** INFORMATION TECHNOLOGY LTD  
Unit 3, Button End Harston Cambridge CB2 5NX England  
Telephone: 0223-871711 Telex: 81687 HITCAM G.

## New Music-Triggered Lighting from Avitec

Avitec unveiled two exciting new music-triggered multi-beam lighting projectors at the recent PLASA Light & Sound Show - both from leading Italian manufacturers.

Nisels' Music Flash utilises eight lenses, in front of which the user can insert any choice of colour gels, and it produces sharp, narrow angle, parallel fanning beams with ultra-fast motorised beam movement and colour change. Requiring only a single mains supply, the unit has an in-built microphone to trigger the motorised fanning sequence directly from the music material being played.

Working on a similar principle, but with a slower, moodier effect, is the 'Ventaglio Musiccolour' from FAL. A development of FAL's best-seller Ventaglio Fanning Beams, Musiccolour comprises five lenses for a choice of colour beams, moves through 180° and, like Music Flash, has an integral mic system which triggers different beams according to the beat of the music.

For further information on both products contact Avitec Electronics (UK) Limited, 80-81 Walsworth Road, Hitchin, Herts SG4 9SX telephone (0462) 58961.

## Studio Series

Home Automation Limited have announced the availability of a new range of commercial light dimmers, to be known as the Studio Series.

The new range will have particular appeal to studios, hotels, conference rooms and audio-visual production companies where there is a

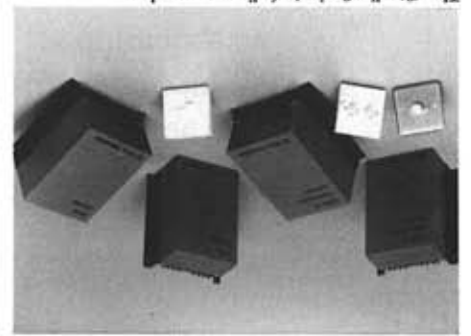

The 'Studio Series' of dimmer packs.

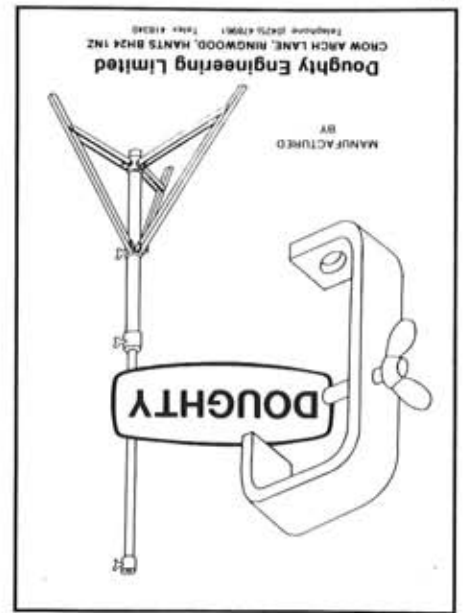

Doughty Engineering Limited  
CHOW ARCH LANE, RINGWOOD, HANTS BH23 1NZ  
Telephone (0253) 479611 Fax: 418348

need to have overall or partial room light level control available. The Studio Series consists of two tungsten high wattage dimmers suitable for wattages of up to 3000 and 5000 watts; four types for use with the new and growing market for low voltage lighting, enabling total wattages of 250, 500, 1500 and 2500 watts to be dimmed; and two versions for the dimming of fluorescent luminaires of 1500 and 2500 watts.

For higher wattages the dimmer box can be placed in a hidden location, with the linear slider dimmer control being placed remotely at the most useful to hand location point. For automated control, a motorised controller is available and it is designed to allow for semi-pre-set light level operation.

Further technical information is available by requesting a copy of a new leaflet available from Home Automation Limited, Pindar Road, Hoddesdon, Herts EN11 0ET.

The Crown CM Series of hand-held mics: CM-100, CM-200, and CM-300.



## Crown CM Series

The new Crown CM series hand-held microphones include the nearly indestructible omni-directional CM-100, the smooth, good-sounding cardioid CM-200, and the new CM-300 sets a new standard for gain-before-feedback. For full details contact Shutesound Limited, Unit 15 Osiers Estate, Osiers Road, London SW18 TEJ telephone 01-871 0966.

**CONDITIONS FOR ADVERTISEMENT IN LIGHTING + SOUND INTERNATIONAL**  
The Publishers reserve the right to refuse any advertisement—whether pre-paid or not—and without reasons being given for any such refusal. The Publishers accept no liability for any loss or damage by an error or inaccuracy in the printing of any advertisement.

# MODERN LIGHTING LTD

ENTERTAINMENT SALES

UNIT 1 • BABBAGE ROAD • STEVENAGE • HERTS • SGI 2ED • ENGLAND  
TELEPHONE: (0438) 317200 • TELEX: 265871 REF DGS1518 MONREF G • E-MAIL: DGS 1517

SM 3030 stereo mixer.

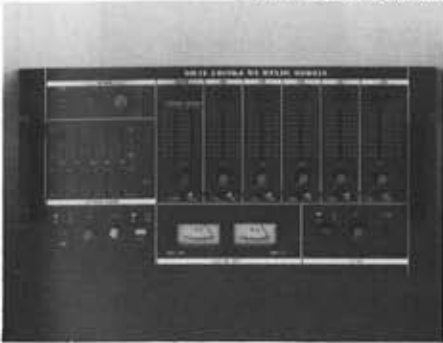

One of the new Profile SMC controller range.



SCC 4000 4-channel chaser from Profile.



The SCC 4000 is a 4-channel chaser which can be used both automatically or sound controlled. It has been specially developed for use in mobile units, small-scale bars, discos and for controlling 4-channel rope lights. Thanks to its multi-design, the unit is able to operate either as a stand-alone unit or installed in disco fittings.

The SMC Controllers are available in four different versions. SMC 80 and 160 are running light controllers, and the SMC 44 and 88 are matrix controllers. They can all be controlled either automatically via music modulation, or in beat with the music light pattern ideas are absolutely unlimited with the various programs such as 'Rip-ple Sound', 'Random Flash' and 'Duo Play'. Com-

## Profile from JiveLight

At the recent PLASA Show in London, JiveLight Limited was appointed exclusive UK distributor for the Profile of Switzerland range of lighting and sound controllers.



pleting the lighting range are the 'Soundscanner', a low budget unit that is sound or automatically controllable and can be used free standing or suspended either vertically or horizontally, and the SLD 2000 sound to light dimmer.

The multi-function SM 3030 stereo mixer features a high quality stereo pre-amplifier, graphic equaliser (5 channel), listen monitoring system, pre-set function, switchable equaliser on/bypass, switchable stereo/mono for microphones, one master control, two tape/tuner controls, two phono controls, mic controls, and increase echo equipment.

For complete product specifications contact Jivelight Limited, 16-18 Greyhound Road, London W6 8NX telephone 01-381 0868.



The flexible Soundscanner low budget unit.

**Sound Equipment Rental and Sales**  
including the 'Hackney Cab' speaker system  
and Yamaha PM 3000 mixing desk

**Sound Design and Engineering**

**Specialist Radio Mic Applications**

West Works Telephone: 01-986 6111  
Chalgrove Road Telex: 265871 Attn: DGS 2220  
London E9 6PB E-Mail: Hardware-UK



**Hardware House**

**THE UNUSUAL  
RIGGING  
CO LTD**

**RIGGING FOR CONCERT THEATRE  
COMMERCIAL FILM T.V. & VIDEO  
PRESENTATION.**

Unit 9, Ferrier Industrial Estate,  
Ferrier Street, London SW18

**01-871 1124**

Telex 945470 Riggin G

**W.M.S.**  
**LIGHTING**  
  
**HIRE  
DESIGN  
ENGINEERS**

Unit 3 St. Margarets Business Centre  
Drummond Place Moor Mead Road  
Twickenham Middlesex TW1 1JN

**01-891 4755**

**"Now you can buy a system at a  
fraction of the cost of the  
competition".....**

*says Managing Director Fergus  
Veitch holding one of PANCAN's  
Compact System 3  
"Moving Light"  
Units*

**CONTROLLABLE  
MOVING  
LIGHTS  
on a LOW  
budget?**



**New Lower Price**

For example, to turn an existing PAR 64 into an intelligent spotlight with fully programmable position and colour change, controlled from your own lighting desk, you need only fit a PANCAN System 3, costing as little as £299 (ex. VAT)

**Highest Quality**

The new high-speed PANCAN System 3 is made from aircraft quality aluminium with Swiss precision motors and MIL spec. transducers. Our units are unbeatable for low price, highest quality and ease of installation directly on to your own existing luminaires.

**PANCAN**

"MOVE THE LIGHT NOT THE LUMINAIRE."  
Pancan, 25 Powis Terrace, London W11 1JJ  
Tel: (01) 221 1455  
Telex: 268 141 METMAC G (Attn Pancan)

**PHONE NOW  
(01) 221 1455**

Telephone our technical  
department for advice and  
your **FREE** information kit.

# MUSHROOM LIGHTING

did you know...

there is a specialist  
company in the heart of  
Northamptonshire that can  
supply all your sound and  
lighting requirements?

To find out more about us  
phone 0604 494866 or  
0604 494991 -  
and maybe we could  
brighten your day.



We are also major  
trade distributors for  
many national sound  
and lighting equipment  
companies.

Please rush me a swatch book and the new Supergel Guide pocket book on the only truly self-extinguishing gel.

Name: \_\_\_\_\_

Company: \_\_\_\_\_

Address: \_\_\_\_\_

**ROSCO**  
**supergel**

Roscolab Ltd., 69 - 71 Upper Ground, London SE1 9PQ  
Telephone: 01-633 9220

Also at New York, Hollywood, Toronto, Madrid & Tokyo

As the saying goes, seeing is believing. What you see above are actual photographs of our main competitor's filters after they were exposed in a real test to the heat of a spotlight.

Then below is Rosco's Supergel after the very same test. It's not hard to see who can take the heat. And who can't.

If you're still sceptical, there's nothing to stop you performing the same test. Pick up some of their filters and put them on hot lights for a while. You've got to admit, it's not every company that invites you to buy from the competition. But we feel pretty confident that it will probably be the last time.

## Ours didn't

After 90 mins



## When we tested our competitor's gels, they did a slow burn.

14 mins



17 mins



20 mins



5 mins



8 mins



11 mins





# DIRECTORY

Lighting + Sound  
Equipment Sale/Hire  
Installation and Design

**Concord Controls** 

## THEATRE LIGHTING

- Good Design
- Reliability
- Systems Designed Free of Charge
- National Distributorship

Phone us for  
Further Information

Unit 3, Dawson Road, Mount Farm  
Bletchley, MK1 1LH (0908) 644366

## SOUTH WEST LIGHTING

Manufacturers and  
Suppliers of Effects  
Lighting to the Trade

Pinspots from £6.00  
4-head Helicopters  
from £55.00  
ALL GUARANTEED

Paul and Jane Goody  
SOUTH WEST LIGHTING  
2 Staplake Road, Starcross, Exeter,  
Starcross (0626) 890806  
AREA DEALERS REQUIRED

**MUSICRAFT**  
LTD.

## LIGHT AND SOUND

LEADING STOCKISTS OF ALL  
LEADING BRANDS INCLUDING:  
CITRONIC - FAL - PULSAR  
OPTIKINETICS - ICE - BOSE - SHURE  
MCKENZIE - QUAD

RSC Franchise dealer

Manufacturers of sound to light units,  
pre-amps, high voltage amplifiers,  
speakers and cabinets.

OVERSEAS ORDERS TAKEN —  
303 Edgware Road, London W2 1BS.  
Tel: 01-402 9729/01-402 2898.

## FIBRE OPTIC LIGHTING

We are specialist manufacturers and  
suppliers of the very widest range of  
Fibre Optics including glass and  
polymer fibre and harnasses, lenses,  
curtain washers, bullet, ball lenses,  
spotlights, light sources, colour  
wheels, edge light interfaces, lamps,  
motors, and transformers.

We also manufacture signs, mirror  
and acrylic displays, starcloths and  
other effects from subtle back-  
grounds to fibre optic fireworks.

Our Chiswick Showroom has numer-  
ous examples of our work (visit by  
appointment).

Trade & Export call PAUL RAYMOND  
Par Opti Projects Ltd.  
Unit 9 The Bell Ind. Est.  
Cunnington St.  
Chiswick Park  
London W4 5EP  
Tel: 01-995 5179



Tel: 93718 PAROP G  
Fax: 01 994 1162

**LE MAITRE**  
**PYROTECHNICS AND**  
**SMOKE/DRY ICE MACHINES**  
**MAIN DISTRIBUTORS FOR**  
**LONDON & SOUTH EAST**

**DONMAR** 



Donmar Ltd 22 Shorts Gardens Covent Garden  
London WC2H 9AU Tel 01 240 3527 Telex 264 892

**J.S.G**

104-108 MAIN STREET, BINGLEY BD16 2JH  
WEST YORKSHIRE

Tel: Bradford (0274) 567268-564389  
561044 - 568843

**Sound Consultants**  
to the  
**Entertainment Industry**

TURBOSOUND DISTRIBUTOR  
(North and Midlands)

MARTIN AUDIO - JBL - ELECTROVOICE - H/H  
BOSE - TANNOY - MATAMP - C.AUDIO  
TECHNICS - TOA - SOUNDRAFT - TRIDENT

## RELAX . . . LX

THE FAST, ONE STOP SUPPLIER  
FOR ALL YOUR LIGHTING NEEDS



LAMPS - CABLES - TRANSFORMERS  
ELECTRONIC FLICKER CANDLE  
RAYLIGHTS - PAR 36, PAR 56, PAR 64  
PAR CANS - LANTERNS  
HOOK CLAMPS - SAFETY CHAINS  
LENSES - LAMP HOLDERS - PLUGS  
SOCKETS - LOW VOLT MINIATURE  
LIGHTING - EFFECTS  
TECHNICAL ADVICE

If you have a problem — or an order  
phone ACTION

TELEPHONE (01) 993 1684/3260  
Stores and Trade Counter open 9-6 Mon-Fri  
367 Uxbridge Road, Acton, London W3 9RH

**LIGHTING  
HIRE  
SALES  
SPECIAL F/X**

STAGE CONTROL LTD.

STATION PARADE,  
WHITCHURCH LANE,  
EDGWARE, MIDDX. HA8 6RW

TEL: 01 952 8982  
TELEX: 924896

**Northern Light**  
Lighting Equipment Hire & Supply

Technical equipment for the leisure and entertainment industry  
Sale \* Installation \* Hire

Stockists for Strand, Hall Stage, Fire Marshall Board, Roscolab,  
Cima Electronic and Theatrescene Effect Edinburgh 031-553 2383

Glasgow 041-440 1771

**NORTHERN  
LIGHTS**

## Sound & Lighting

### Distributors

Trade representation for

**OPTIKINETICS**  
**POWERDRIVE**  
**ANYTRONICS**  
**LE MAITRE**  
**TEXTLITE**  
**ZERO 88**  
**PULSAR**  
**CLOUD**  
**SHURE**  
**SATEL**  
**MODE**  
**EDC**  
**ICE**

89 Scotforth Road, Lancaster.  
Tel: 0524 62634.

## NIGHT FLIGHT

Sound and Lighting

**THE BIG ONE IN  
SCOTLAND**

Installation, Design,  
Hire, Repair and Service  
0389-79261

## LIGHTING HIRE & SALES

**Philip L. Edwards**  
(Theatre Lighting)

5 Highwood Close, Glossop,  
Derbyshire SK13 9PH.  
Telephone: 04574 62811.

**SPOT ON  
FOR QUALITY**



Sound, Lighting and special  
effects for leisure, promotion,  
entertainment and the arts.

- First class technical back-up.
  - In-depth stocking at the best prices.
  - Speedy mail order and expert service.
  - Instant credit to qualifying customers.
  - Also suppliers to trade.
- Brochure on request.

**LUTON SOUND & LIGHTING**

75 & 82-88 Wellington Street,  
Luton, LU1 5AA, England.  
Telephone: 0582 411733 (5 lines)  
Telex: 825353/825562 CHACOM G LITECO



**Telephone (029673) 8255**  
**Steeple Claydon, Buckinghamshire.**  
**Office 16 Chaltoners Hill**  
**Show Room 10 Chaltoners Hill**

- \* Large Showroom/Pop Video Filming Facility
- \* Agents for SATEL + most other makes of motorised lighting sold
- \* Full repair, and 24-hour Breakdown Service
- \* Hire Service available on most special effects - telephone for Catalogue
- \* New and Second-hand Equipment bought and sold
- \* Installation work undertaken

**SOUND & LIGHTING**  
**INSTALLATIONS**

**Tantasia**

**Mico Lighting Ltd.**  
 Trovate Lane, Pudsey, Leeds, West Yorkshire.  
 Telephone: (0532) 567113  
 Telex: 556469 (MICO G)

U.K. Distributor for Philips/Westinghouse, LAMPS used in the THEATRE and ENTERTAINMENT industries.

The specialist for LAMPS used in the THEATRE and ENTERTAINMENT industries.

Philips/Westinghouse, U.S.A. Excellent Trade terms available.

**DESIGNERS & PRODUCERS OF STAGE LIGHTING EQUIPMENT & CONTROL**

**Great West Lighting**  
 TEL (0703) 222667

**MUSHROOM LIGHTING**

The professional people. Specialists in supplying all your sound and lighting requirements. For Hire or Sales phone 0604 494866 or 494991

**STAGE LIGHTING**

**OUT SALE HIRE**

**CCT theatre lighting limited**  
 WINDSOR HOUSE, 26 WILLOW LANE, MITCHAM, SURREY, CR4 4NA TEL: 01 640 3368 TELEX: 946648

Mon-Fri 9.30 am - 5.30 pm.  
 Export Sales - Trade Shows

- 500W FLOODS
- 1000W FLOODS
- VARIABLE BEAM
- PROFILE SPOTS
- FRESNEL SPOTS
- PEBBLE CONVEX SPOTS
- DIMMING AND CONTROL
- COLOUR CHANGE
- EFFECTS
- RIGGING EQUIPMENT



**METEORLITES**

● THE MOST EXTENSIVE WORLDWIDE STOCK OF THOMAS TRUSSING AND GROUND SUPPORT SYSTEMS AND ACCESSORIES.

● COMPREHENSIVE RANGE OF MOTORS, HOISTS, LIFTS AND RIGGING HARDWARE.

● FULL RANGE OF STAGE AND TV LIGHTS, INCLUDING: PROFILES, FRESNELS, FOLLOW SPOTS, GROUNDROWS, CYC LIGHTS, 8-LITES, 2, 5 AND 10 KW HEADS.

● VARIED SELECTION OF PRODUCTION EQUIPMENT, INCLUDING: SCISSOR LIFTS, WORK PLATFORMS, PROJECTORS, SCREENS, RISERS, STAGE FLOORS, SCENERY AND DRAPES.

IN THE U.K. AND EUROPE CONTACT: TONY PANICO — Equipment hire and support services. — TV, theatre and commercial productions. ROMAN WILLSON — Rock and Roll touring productions.

IN THE AMERICAS AND THE PACIFIC CONTACT: BILLY JONES — Equipment hire and support services. — Touring productions. DIZZY GOSNELL — Touring productions. ROMAN WILLSON — Touring productions.

● LARGE STOCKS OF AVOLITES, DIMMERS, DESKS AND MOTOR CONTROL SYSTEMS.

● CELCO DESKS AND COLOUR CHANGERS.

● UNIQUE MODULAR ALUMINIUM TAB TRACK SYSTEMS.

● SPECIAL EFFECTS SERVICE FOR PYROTECHNICS, SMOKE AND DRIE-ICE MACHINES.

● COMPLETE TOURING SYSTEMS WITH DESIGN AND CREW, OR STRAIGHT EQUIPMENT HIRE.

● WORLDWIDE SERVICE AND BACK-UP.

● MODULAR TRUCK PACK GUARANTEES ECONOMIC TRUCKING.

AT: METEORLITES PRODUCTIONS INC., 20 NORTH MULBERRY STREET, HAGERSTOWN, MARYLAND 21740 U.S.A. TELEPHONE: (301) 733 3855 TELEFAX: 490001631 MET UI E-MAIL: IMC1796

**TSL**

SOUND & LIGHTING, A.V. and VIDEO HIRE, MOVING OPTICAL EFFECTS MANUFACTURERS CLEAR.COM INTERCOM SYSTEMS - UK Distributors Over-the-Counter Sales of CCT Lanterns, Lamps, Colour, Gobos, etc.

67 BRURY LANE, LONDON WC2B 5JF  
 Telephone: 01-836 6902 01-379 5433

**TRAFALGAR LIGHTING LTD.**

01-360 0936 SALES-HIRE LIGHTING BOUGHT & SOLD

01-360 0936

**W.B. Group**

cover the complete lighting spectrum from film to TV, theatre to disco special & motorised effects

Only the best is good enough

**W.B. Group**  
 4 Tenter Rd., Moulton Park Ind. Est., Northampton NN3 1PZ  
 Tel: (0604) 499331



**MAC manchester**

Professional sound hire nationwide

High quality communications systems

Sales and service facilities

1 & 2 Attenburys Park, Park Road, Altrincham, Cheshire, WA14 5QE.  
 Telephone 061-969 8311





Light years...

...in seconds

Take control. Light up your own universe; you have 500 circuits at your fingertips.

Dynamic Technology's Datalite Modular Control System is ergonomically superb, and the creative power at your command can take your breath away. Yet such is the flexibility of the Datalite system that it is equally suitable for a 64-circuit news studio. The system is individually tailored to an operator's exact needs.

Each function is served by a single dedicated control, and every control is positioned on the console just where you would expect it to be. The unique design allows for infinite variations in console make-up. Standard features include switched previewing and lamp failure sensors; additional modules can



be added at any time and the options are extensive.

Datalite is the only lighting system providing such versatility without incorporating hugely expensive electronic circuitry and additional software. It is one of several DTL lighting control systems, the products of wide-ranging practical experience of broadcast technology requirements, original research and engineering excellence.

You're in charge. And with DTL in your corner, you're light years ahead.

**Dynamic Technology Limited**  
13 Cumberland Avenue,  
Park Royal, London NW10 7RH.  
Telephone: 01-961 4986  
Telex: 8951540 Fax: 01 965 2216





**Hire•Sales•Service**

- \* Lighting
- \* Sound
- \* Curtains
- \* Track
- \* Connectors
- \* Make-Up
- \* Scenics
- \* Pyrotechnics

Theatre • Disco • Display • Architectural

Highdown Industrial Estate,  
Hamshire BH24 1ND  
Crow Arch Lane, Ringwood,  
Hants

Sales 0425 470888 Hire 0425 470888



**eurolight**

Lighting Controls  
Stage Management Systems  
Patching Systems  
Paging and Relay Systems  
Full Installation Service

EUROLIGHT LTD.  
Unit 8, Maple Industrial Estate  
Maple Way,  
Feltham TW13 7AW  
England  
Telephone: 01-751 6400  
Telex: 888941 LCCI LITESVM

FOR ALL  
YOUR  
CONTROL  
REQUIREMENTS

**Dial Sound & Lighting**

Wholesale Distribution for

**BOSE** **RAMA**  
**OPTOMETRICS** **ZERO 88**  
**ROSCO** **GOEMAR** **PULSAR**  
**POWER DRIVE** **TECHNICS** **JBL** **Le Maître**  
**MODE ELECTRONICS**

Specialist supplier of Mini Light Tube  
INSTALLATION DIVISION — SHIPLEY DIAL LTD.

DIAL SOUND AND LIGHTING  
Unit 4G Wharfedale Road, Euroway Industrial Estate,  
Bradford BD4 6SG.  
Telephone: (0274) 687605

**FUTURIST**  
THEATRICAL HIRE LTD

FOR HIRE AND FOR SALE  
CINEMOID & SPECIAL EFFECTS  
EQUIPMENT & LIGHTING

FOR ALL THEATRICAL PRODUCTIONS

Full Range of Lamps  
Full Range of Special Effects  
Cinemooid & Special Effects  
Equipment & Lighting

HOYLE HEAD MILLS, NEW ST.  
EARLSHEATON, DEWSBURY,  
W YORKS WF13 8JL

Tel: (0924) 468183

Strand Lighting Main Dealer and Service Agent

**LHS**

Leslie Hire & Sale

For  
Stage and TV Lighting,  
and Stage Equipment,  
phone  
01 871 5132

L.H.S. Limited, The Business Village, Brookfield Road,  
Wandsworth, London, SW18 4JG  
Telex: 917003 LFCG

**Starlight Design**

Supply and installation  
of Lighting and Sound  
for Clubs and  
Discotheques  
FULL DESIGN SERVICE  
Trade/Export Enquiries  
Welcomed

Starlight Design, 9 Alms Hill,  
Bourn, Cambs, CB3 7SH  
Tel: (0954) 8841

**WHITE LIGHT**

57 Filmer Road - London SW6  
Tel: 01-731 3291  
Telex: 295811

THEATRE LIGHTING  
HIRE AND SALES

Our prices are competitive  
please ring for price list or quote

NORTHERN BRANCH  
55M HILL LANE, THIRSK, NE 14 6JX  
WEST YORKSHIRE TEL: HAYLAK (0423) 82076

**Strand Lighting**

- Stage & TV Lighting
- Lighting Control
- Equipment
- Effects Projectors
- Colour Filters
- Dealers throughout the UK

P.O. Box 51, Great West Road,  
Brentford, Middlesex TW8 9HR.

015603171

**L Lancelyn Lighting**

Lighting Hire & Sales  
Make-Up, Control, Rosters,  
Pyrotechnics and Effects.

HIRE Oxford (0865) 725222  
SALES Oxford (0865) 511522

Lancelyn Lighting Northwest: 051-334 8991

**J.M.S. LIGHTING**

Lighting Design  
Equipment Rental  
Lighting Engineers

London 01-691 4755

**ANYtronics**

manufacturers of high quality

- \* Strobes
- \* Lighting Control
- \* Equipment
- \* Amplification

trade & export enquiries  
most welcome

Anytronics Limited  
6 Hillside Ind. Estate  
London Rd, Horsham  
Hants. PO8 0BL, England

Tel: (0705) 599410  
Telex: 869185

**UPDATE**

- \* Sound and lighting equipment hire
- \* Le Maître special effects stockist
- \* Installation service and one night stands available
- \* Special promotions and competitive rates and efficient service
- \* Call us for colour brochure and price lists

STAGE TWO LTD  
197 Watford Road, Croxley Green,  
Herts WD3 3EH  
Watford (0823) 30789

**MODERN WORLD LIGHTING LTD**

CONTACT JOHN JACKSON FOR ALL YOUR ENQUIRIES OR CALL ON US  
BY ROAD—OFF THE A1(M) JUNCTION 8 OR 7 (BY KNEBWORTH HOUSE),  
CENTRAL LONDON—1 HOUR; M25—15 MINUTES; HEATHROW—45 MINUTES.  
BY RAIL—STEVENAGE STATION ON THE KINGS CROSS TO EDINBURGH LINE;  
35 MINUTES FROM KINGS CROSS.

UNIT 1 • BABBAGE ROAD • STEVENAGE • HERTS • SGI 2ED • ENGLAND  
TELEPHONE: (0438) 317200 • TELEX: 265871 REF DGS158 MONREF G • E-MAIL: DGS 1517

**black light**

Scotland's lighting company

DEALER FOR  
HIRES AND SALES

CCT  
AARI  
ROSCO  
ZERO 88  
GOEMAR  
LE MAITRE  
DURAPLUG  
POWERDRIVE

01 551 2111  
24 HOUR 7 DAY  
01 274 4936  
BROADWAY 92





**LHS**  
Leslie Hire & Sale

For  
**Stage and TV Lighting  
and Stage Equipment,  
phone  
01 871 5132**

L.H.S. Limited, The Business Village, Broomhill Road,  
Wandsworth, London SW18 4JQ  
Telex: 912003 LPC G

**Elliott Bros.**  
▶ **Audio**  
▶ **Video**  
▶ **Comms**

**Installation  
& Supply  
0865 249259**

**S.A.V.**

**SOUND + LIGHTING  
DISTRIBUTORS**

**SALES & HIRE**

**Optikinetics  
Powerdrive  
Le Maitre  
Zero 88  
Pulsar  
Bose  
AKG  
CCT  
Tannoy  
Coemar  
System Freestyle  
etc.**

**STARDREAM AUDIO VISUAL**  
Party House, Mowbray Drive,  
Blackpool, Lancs.  
**Telephone: (0253) 302602**  
Telex: 67426 PARTY G



**BACK NUMBERS**  
of Lighting+Sound  
International  
are available  
@ £1.50 each (inc. p & p)

Ring (0323) 642639  
for details



- Library and Custom made Gobos and Slides.
- Screen Printing onto various Materials.
- Standard and Custom Fibre-Optic Effects and Equipment.

For further information Contact:

**DHA Lighting Ltd., 7 Bishops Terrace,  
Kennington, London SE11 4UE.  
Tel: 01-582 3600 Telex: 935639 Goboco G**

**NIGHT FLIGHT**

Sound and Lighting  
**THE BIG ONE IN  
SCOTLAND**

Installation, Design,  
Hire, Repair and Service  
**0389-79261**

## Creative lighting starts here



Look to  
**Strand for versatility  
and reliability in Stage Lighting equipment.**  
The range answers every need – from  
professional productions to amateur and  
educational requirements from civic centres  
to discos and small clubs.  
For more information contact your  
nearest Distributor.

**A.S. Green & Company Ltd.**  
**Stage Products**  
Winchester Road,  
Haydock Lane Industrial Estate,  
Haydock, Merseyside WA11 9XQ.  
Telephone: Ashton-in-Makerfield  
(0942) 718347

**Caithness Stage & Lighting  
Limited**  
22 New Street, Weighhouse Close,  
Paisley PA1 1YB, Strathclyde.  
Telephone: 041-887 0949

**Commerical Electronics**  
Jersey International House,  
5 Columbus Street, St. Helier, Jersey,  
Channel Islands.  
Telephone: Jersey Central  
(0534) 35348

**Futurist Theatrical Hire Ltd.**  
Hoyle Head Mills, New Street,  
Earlsheaton, Dewsbury,  
W. Yorkshire WF12 8JJ.  
Telephone: Dewsbury (0924) 468183

**General Engineering Products  
Limited**  
8 Lorne Street, Belfast BT9 7DU.  
Telephone: Belfast (0232) 664411

**J.B.E. Stage Lighting &  
Equipment Co.**  
Union Lane, Rochford,  
Essex SS4 18AP.  
Telephone: Southend-on-Sea  
(0702) 545826.

**Light Relief**  
Eillar House,  
Alexandra Industrial Estate,  
Wentloog Road, Rumney, Cardiff,  
South Glamorgan.  
Telephone: Cardiff (0222) 779555.

**L.H.S. Limited**  
The Business Village, Broomhill Road,  
Wandsworth, LONDON SW18 4JQ.  
Telephone: 01-871 5132.

**Luff Light & Sound**  
36-38 Gautrey Road, Nunhead,  
LONDON SE15 2JQ  
Telephone: 01-639 7705

**Midland Theatre Services Ltd.**  
Chapel Street, Handsworth,  
Birmingham B21 0PA.  
Telephone: 021 554 2131

**Northern Light**  
39-41 Assembly Street, Leith,  
Edinburgh EH6 7RG.  
Telephone: 031-553 2383

**Northern Light**  
79 Loanbank Quadrant, Govan,  
Glasgow G51 3HZ.  
Telephone: 041-440 1771

**Sound Electronics,  
(Newcastle) Ltd.**  
201-215 Jesmond Road,  
Newcastle upon Tyne,  
Tyne & Wear NE2 1LA.  
Telephone: (091) 281 4248

**Stage Electrics**  
Cofton Road, Marsh Barton,  
Exeter EX2 9QW.  
Telephone: Exeter (0392) 55868

**Stage Electrics**  
Unit 9 Victoria Rd, Avonmouth,  
Bristol BS11 9DB.  
Telephone: Bristol (0272) 827282

**Stage Electrics**  
29 Holly Court, St. Modwen Road,  
Parkway, Plymouth, Devon PL6 8LG.  
Telephone: (0752) 269444

**Stage Lighting Centre**  
Glansvern House, 108 Pearse Street,  
Dublin 2.  
Telephone: Dublin (0001) 770880 or  
710414 or 770397



**Strand Lighting**

PO Box 51, Great West Road, Brentford, Middlesex TW8 9HR, United Kingdom  
Telephone: 01 560 3171 Telex: 27976

LOS ANGELES: 18111 South Santa Fe Avenue, PO Box 9004 Rancho Dominguez, California, 90224 U.S.A.  
TORONTO: 6490 Viscount Road, Mississauga, Ontario L4V 1H3, Canada.  
BRAUNSCHWEIG: 3340 Wolfenbüttel 16, Salzdahlum, West Germany.  
HONG KONG: 802 Houston Centre, 63 Mody Road, Tsimshatsui East, Kowloon.  
OFFICES: PARIS, NEW YORK, ROME, MELBOURNE.



**LIGHTING SOUND International**  
 7 Highlight House  
 St Leonards Road  
 Eastbourne  
 East Sussex  
 BN21 3UH

**For annual advertising rates in the DIRECTORY section of**  
**LIGHTING SOUND International**  
 telephone  
**(0323) 642639**

**ELECTRICAL CONTRACTING**

**GLANTRE ENGINEERING LTD**  
 Valley Street, Reading, Berkshire RG1 1GF  
 Tel: 0734-509711  
 Telex: 648522

**ECA**

- For theatres, studios, halls, clubs and commercial presentation.
- Design, supply and installation of lighting, sound, stage equipment, rigging, AV, conference and projection systems.
- Packages a specialty.
- UK and international.

**The Best Of British**

Filled Cloth and Sharkstooth Gauze  
 IN STOCK NOW

**GENSETS**

Unit 19B  
 Tower Workshops  
 Riley Road  
 London SE1 3DC  
 Tel: 01-237-0041

**get on the right tack!**

Printed Tapes + Labels.  
 Anti-Slip Flooring.  
 Electrical + Double Sided Tapes.  
 T.V. Studio Vinyl Flooring.  
 Genuine American Gaffer Tape  
 and much, much, more  
 Call us for Brochure and Price List  
**Mark self-adhesives Ltd.**  
 Unit 24, Stephenson Way, St Ives,  
 Cambridgeshire PE17 4WJ  
 Tel: Huntingdon (0480) 494540

**THE ZODIAC**  
 WINCHED EQUIPMENT STAND

**Challenge** PRODUCT

The lightweight stand with a sliding triple mast designed to support anything from lighting trusses to speaker systems.  
 Lifting capacity 200kg to a height of 5.1M  
 Operated with ease by one person.  
 AVAILABLE FROM:  
**GRAPVINE**  
 SOUND AND LIGHT  
 Enterprise House,  
 10 White Road,  
 Farnham Industrial Estate,  
 Wimborne, Dorset BH21 7PL.  
 Tel: (0202) 893665

**UNI-TRACK**

**TRIPLE E LTD.**  
 Precision Stage Hardware  
 London  
 ENGLAND  
 01-237 6354

*We are Light Years Ahead*

From simple open/hut to multi-function computer linked cross ladders, flying, accelerating with instant stops, and slant too. We can move anything with the Linear-Motor-Driven **CURTAIN**

**Designer Structures**

Aluminium Trusses built to your specification at our factory Lightweight, Standard or Heavyduty Structures and Ground Supported Systems for Sale or Hire  
 Phone Pam (0752) 663777 or write UPSTART COMPANY PO Box 88, Plymouth PL1 1SZ

**Hall Stage Products Limited**

offer a complete range of Rigging Gear, Pulleys & Curtain Tracks for the discerning designer

**HALL STAGE PRODUCTS**  
 Chris Hitchens  
 The Gate Studios, Station Road, Borehamwood, Herts WD6 1DQ.  
 Tel: 865602 PERLU-G  
 Telephone: 01-953 9371/2.

For the latest literature write or telephone:

**THE HARDCASTE COMPANY**

SPECIALISTS IN FLIGHT CASES FOR THE MUSIC INDUSTRY, AUDIO, VIDEO, PHOTOGRAPHIC & COMPUTERS

SOLVENT BUSINESS CENTRE  
 UNIT 001  
 MILLBROOK ROAD WEST  
 MILLBROOK  
 SOUTHAMPTON SO1 0HW  
 Tel: (0703) 780333

**FILTERS**  
 BIGGEST STOCK & WIDEST RANGE IN THE COUNTRY!

Including ROSCO SUPERGEL, ROSCOLENE, CINECOLOR, CINEGEL, LEE FILTERS, CHRIS JAMES FILTERS

Always in stock over 10,000 sheets of filter.  
 Four hour delivery service within the city of London

**ORDER ON OUR SPECIAL FILTERLINE No.....**

**0800 282726** PHONE FREE!

**M5L**  
 MIKE SWEETLAND LIGHTING (SALES) LTD  
 10-16 Mercer St, London WC2 9QE.  
 FAX: 01-240 0033  
 44 Higher Ardwick, Manchester M12 6DA.  
 FAX: 061-273 3640





VIA S. DOMENICO, 65 - C.P. 11  
72019 S. VITO DEI NORMANNI (BR)  
ITALY

TEL. 831/392136  
TLX. 813890  
FAX. 831/392841

ILLUMINATED... IDEAS!!!



DOUBLE BARRIER



MINI FOLLOWSPOT



PIOVRETTA



POLIFEMO



SMOKE BUBBLE MACHINE



ELECTRONIC ANIMATION  
SCENE' PROJECTORS  
LIGHT'S GAMES  
SPECIAL EFFECTS



- MODE ELECTRONICS LIMITED**  
Cheking Lodge, Tonwell, Nr. Ware, Herts.  
Tel: (0920) 2121.  
Contact: Richard Seward, Technical Director; John Bradbrook, Commercial Manager. Manufacturers of discotheque lighting control equipment, dimmers and effects.
- MODERN WORLD LIGHTING LTD**  
Unit 1, Babbage Road, Stevenage, Herts SG1 2ED.  
Tel: (0438) 317200.  
Tel: (0438) 317200.
- MUSICRAFT LTD**  
303 Edgware Road, London W2 1BN.  
Tel: 01-402 2898/9729.  
Contact: Jack or Annu. Manufacturers of discotheque and lighting equipment, specialising in worldwide export.
- MYSTICAL LIGHTING**  
23 Low Farm Place, Moulton Park Industrial Estate, Northampton.  
Tel: (0604) 491737.
- NIGHT FIGHT SOUND & LIGHTING**  
Torwood, Bowling, Strathclyde, Glasgow C60 5AB.  
Tel: (089) 79261.  
Contact: Bill Smith, Senior Partner; Nik Fraser, Office Manager. Design, installation, repairs and hire with full time experienced staff on call 24 hours. Agents for most manufacturers. Large stocks.
- N.J.D. ELECTRONICS LIMITED**  
11 Ascot Industrial Estate, Lewton Street, Sandanger, Northham.  
Tel: (0602) 394122.
- NORTHERN LIGHTS**  
89 South Road, Lancaster LA1 4SD.  
Tel: 0524 62634.  
Contact: Ray Wilkinson, Partner. Sales, hire and wholesale distribution of sound, lighting and special effects products.
- OPTIKNETICS LTD**  
38 Cornwall Road, Luton LU3 1DN.  
Tel: (0582) 411413.  
Telex: 825920.  
Contact: Alan Carwell, Product Manager. Distributors of high quality domestic and professional pick-up cartridges.
- P.A. INSTALLATIONS**  
Enterprise House, 30 Rokeman Street, Lanelli, Dyfed SA15 1SA.  
Tel: (0554) 752490.
- PANCAN LTD**  
25 Powis Terrace, London W11 1JJ.  
Tel: 01-221 1455.  
Manufacture of light moving systems. Control is either direct with joystick, via computer for preset positioning or from a lighting board.
- PAR OPTI PROJECTS LTD**  
Unit 9, The Bell Industrial Estate, Cunningson Street, Chiswick, London W4 5EP.  
Tel: 01-995 5179.
- PECASUS SOUND & LIGHT**  
44 Rodney Street, Edinburgh EH7 4DX.  
Tel: 031-556 1300.
- PICKERING (UK) DISTRIBUTION**  
24 Cillygate, York YO3 7EQ.  
Tel: (0904) 642463.
- POWERDRIVE DRUM CO. LTD**  
Unit M1, Cherrycourt Way, Stanbridge Road, Leighton Buzzard, Bedfordshire LU7 8UH.  
Tel: (0525) 370292.
- RF ELECTRONICS LTD**  
Unit 2, Cotton Road, Wincheap Industrial Estate, Canterbury, Kent CT1 3RB.  
Tel: (0227) 454778.
- JAMES THOMAS ENGINEERING LTD**  
Station Approach, Peshore Trading Estate, Worcestershire WR10 2DB.  
Tel: (0386) 553002.
- JASCO LIGHT & SOUND LTD**  
Unit 10, 315 Summer Lane, Hockley, Birmingham B19 3RH.  
Tel: 021-359 7261
- J.E.W. SMOKE MACHINE CO. LTD**  
Malby House, London Road, Louth, Lincolnshire LN11 9QP.  
Tel: (0507) 607835.
- R.G.JONES SOUND ENGINEERING**  
Beulah Road, Wimbeldon, London SW19 3SB.  
Tel: 01-540 9881.
- LASER CREATIONS LTD**  
55 Merthyr Terrace, Barnes, London SW13 9DL.  
Tel: 01-741 5747.  
Contact: Patric de Vaux, Sales. Lasers for lighting displays and installations featuring the series 9 state of the art controller as featured in the Hippodrome.
- LASER SYSTEMS LTD**  
Unit 11, Lanerham Park, Cwmbran, Gwent NP44 3AX.  
Tel: (06333) 62500/73222.
- LE MAITRE LIGHTING & EFFECTS**  
316 Purley Way, Croydon CR0 4XJ.  
Tel: 01-688 9258.  
Tel: 883220.  
Contact: Mick McKanus, Partner; Rodney Clark, Sales Manager. Manufacturers of pyrotechnics, smoke machines, lighting and other related products for the entertainment industries.
- LEAMINGTON SIGHT & SOUND**  
Unit 17, Kibby Close, Heartcore Ind. Estate, Leamington Spa, Warwick.  
Tel: (0926) 833617.
- LIGHT ENGINEERING LTD**  
64a Ecken Road, Walthamstow, London E17 9YF.  
Tel: 01-520 233677.  
Contact: Stephen Demeza, General Manager; Neil Preen, UK Sales Representative. Manufacture, supply and distribution to the trade of: sound, lighting and special effects. Specialists in installation and design.
- LIGHT SYSTEMS**  
Unit 3, Bartlett Court, Lynx Trading Estate, Yeovil, Somerset BA20 2PT.  
Tel: (0935) 26743.
- LIGHTFACTORY LTD**  
71 Farway Drive, Fairway Industrial Estate, Greenford, Middlesex UB6 8PW.  
Tel: 01-575 5566.
- LIGHTING AND SOUND SERVICES**  
237 Chester Road, Helsby, Cheshire W46 OAD.  
Tel: 092-82 3502.
- LUTON SOUND & LIGHTING LTD**  
75 & 82-88 Wellington Street, Luton, Bedfordshire LU1 5AA.  
Tel: (0582) 411733 (5 lines).
- CONTACT: Mike Henden, Sales Director**
- FANTASIA SOUND & LIGHTING**  
16 Chaltoners Hill, Steeple Claydon, Bucks.  
Tel: (0247) 462338.
- FANTASIA SOUND & LIGHTING**  
Northern Ireland BT19 2EX.  
9 Seabird Crescent, Bangor, Co. Down, NI.  
Tel: 01-240 3527.
- FORMULA SOUND LTD**  
Stuart Road, Ashton Road, Redbury, Stockport, Cheshire SK6 2SR.  
Tel: 061-494 5650.
- GENERAL ELECTRIC USA**  
10 Prospect Way, Royal Oak Industrial Estate, Daventry, Northants NN11 5PL.  
Tel: (0327) 77683.
- HARMAN (AUDIO) UK LTD**  
Mill Street, Slough, Berks.  
Tel: (0753) 76911.
- HAZEL GROVE MUSIC COMPANY LTD**  
Bulkeley House, Stockport Road, Cheshire, Cheshire SK8 2AA.  
Tel: (061-491) 1068.
- HILL AUDIO LTD**  
Hollingbourne House, Hollingbourne, Maidstone, Kent ME17 1QJ.  
Tel: (062 780) 555.
- ICELECTRICS LTD**  
22 Woolmer Way, Bordon, Hants GU35 9QF.  
Tel: (04203) 87128.
- MICO LIGHTING LTD**  
Troyle Lane, Pudsey, Leeds LS28 9LD.  
Tel: (0532) 567113.
- LASER CREATIONS LTD**  
55 Merthyr Terrace, Barnes, London SW13 9DL.  
Tel: 01-741 5747.  
Contact: Patric de Vaux, Sales. Lasers for lighting displays and installations featuring the series 9 state of the art controller as featured in the Hippodrome.
- LASER SYSTEMS LTD**  
Unit 11, Lanerham Park, Cwmbran, Gwent NP44 3AX.  
Tel: (06333) 62500/73222.
- LE MAITRE LIGHTING & EFFECTS**  
316 Purley Way, Croydon CR0 4XJ.  
Tel: 01-688 9258.  
Tel: 883220.  
Contact: Mick McKanus, Partner; Rodney Clark, Sales Manager. Manufacturers of pyrotechnics, smoke machines, lighting and other related products for the entertainment industries.
- LEAMINGTON SIGHT & SOUND**  
Unit 17, Kibby Close, Heartcore Ind. Estate, Leamington Spa, Warwick.  
Tel: (0926) 833617.
- LIGHT ENGINEERING LTD**  
64a Ecken Road, Walthamstow, London E17 9YF.  
Tel: 01-520 233677.  
Contact: Stephen Demeza, General Manager; Neil Preen, UK Sales Representative. Manufacture, supply and distribution to the trade of: sound, lighting and special effects. Specialists in installation and design.
- LIGHT SYSTEMS**  
Unit 3, Bartlett Court, Lynx Trading Estate, Yeovil, Somerset BA20 2PT.  
Tel: (0935) 26743.
- LIGHTFACTORY LTD**  
71 Farway Drive, Fairway Industrial Estate, Greenford, Middlesex UB6 8PW.  
Tel: 01-575 5566.
- LIGHTING AND SOUND SERVICES**  
237 Chester Road, Helsby, Cheshire W46 OAD.  
Tel: 092-82 3502.
- LUTON SOUND & LIGHTING LTD**  
75 & 82-88 Wellington Street, Luton, Bedfordshire LU1 5AA.  
Tel: (0582) 411733 (5 lines).
- CONTACT: Mike Henden, Sales Director**
- FANTASIA SOUND & LIGHTING**  
16 Chaltoners Hill, Steeple Claydon, Bucks.  
Tel: (0247) 462338.
- FANTASIA SOUND & LIGHTING**  
Northern Ireland BT19 2EX.  
9 Seabird Crescent, Bangor, Co. Down, NI.  
Tel: 01-240 3527.
- FORMULA SOUND LTD**  
Stuart Road, Ashton Road, Redbury, Stockport, Cheshire SK6 2SR.  
Tel: 061-494 5650.
- GENERAL ELECTRIC USA**  
10 Prospect Way, Royal Oak Industrial Estate, Daventry, Northants NN11 5PL.  
Tel: (0327) 77683.
- HARMAN (AUDIO) UK LTD**  
Mill Street, Slough, Berks.  
Tel: (0753) 76911.
- HAZEL GROVE MUSIC COMPANY LTD**  
Bulkeley House, Stockport Road, Cheshire, Cheshire SK8 2AA.  
Tel: (061-491) 1068.
- HILL AUDIO LTD**  
Hollingbourne House, Hollingbourne, Maidstone, Kent ME17 1QJ.  
Tel: (062 780) 555.
- ICELECTRICS LTD**  
22 Woolmer Way, Bordon, Hants GU35 9QF.  
Tel: (04203) 87128.
- MICO LIGHTING LTD**  
Troyle Lane, Pudsey, Leeds LS28 9LD.  
Tel: (0532) 567113.
- LASER CREATIONS LTD**  
55 Merthyr Terrace, Barnes, London SW13 9DL.  
Tel: 01-741 5747.  
Contact: Patric de Vaux, Sales. Lasers for lighting displays and installations featuring the series 9 state of the art controller as featured in the Hippodrome.
- LASER SYSTEMS LTD**  
Unit 11, Lanerham Park, Cwmbran, Gwent NP44 3AX.  
Tel: (06333) 62500/73222.
- LE MAITRE LIGHTING & EFFECTS**  
316 Purley Way, Croydon CR0 4XJ.  
Tel: 01-688 9258.  
Tel: 883220.  
Contact: Mick McKanus, Partner; Rodney Clark, Sales Manager. Manufacturers of pyrotechnics, smoke machines, lighting and other related products for the entertainment industries.
- LEAMINGTON SIGHT & SOUND**  
Unit 17, Kibby Close, Heartcore Ind. Estate, Leamington Spa, Warwick.  
Tel: (0926) 833617.
- LIGHT ENGINEERING LTD**  
64a Ecken Road, Walthamstow, London E17 9YF.  
Tel: 01-520 233677.  
Contact: Stephen Demeza, General Manager; Neil Preen, UK Sales Representative. Manufacture, supply and distribution to the trade of: sound, lighting and special effects. Specialists in installation and design.
- LIGHT SYSTEMS**  
Unit 3, Bartlett Court, Lynx Trading Estate, Yeovil, Somerset BA20 2PT.  
Tel: (0935) 26743.
- LIGHTFACTORY LTD**  
71 Farway Drive, Fairway Industrial Estate, Greenford, Middlesex UB6 8PW.  
Tel: 01-575 5566.
- LIGHTING AND SOUND SERVICES**  
237 Chester Road, Helsby, Cheshire W46 OAD.  
Tel: 092-82 3502.
- LUTON SOUND & LIGHTING LTD**  
75 & 82-88 Wellington Street, Luton, Bedfordshire LU1 5AA.  
Tel: (0582) 411733 (5 lines).
- CONTACT: Mike Henden, Sales Director**
- FANTASIA SOUND & LIGHTING**  
16 Chaltoners Hill, Steeple Claydon, Bucks.  
Tel: (0247) 462338.
- FANTASIA SOUND & LIGHTING**  
Northern Ireland BT19 2EX.  
9 Seabird Crescent, Bangor, Co. Down, NI.  
Tel: 01-240 3527.
- FORMULA SOUND LTD**  
Stuart Road, Ashton Road, Redbury, Stockport, Cheshire SK6 2SR.  
Tel: 061-494 5650.
- GENERAL ELECTRIC USA**  
10 Prospect Way, Royal Oak Industrial Estate, Daventry, Northants NN11 5PL.  
Tel: (0327) 77683.
- HARMAN (AUDIO) UK LTD**  
Mill Street, Slough, Berks.  
Tel: (0753) 76911.
- HAZEL GROVE MUSIC COMPANY LTD**  
Bulkeley House, Stockport Road, Cheshire, Cheshire SK8 2AA.  
Tel: (061-491) 1068.
- HILL AUDIO LTD**  
Hollingbourne House, Hollingbourne, Maidstone, Kent ME17 1QJ.  
Tel: (062 780) 555.
- ICELECTRICS LTD**  
22 Woolmer Way, Bordon, Hants GU35 9QF.  
Tel: (04203) 87128.
- MICO LIGHTING LTD**  
Troyle Lane, Pudsey, Leeds LS28 9LD.  
Tel: (0532) 567113.
- LASER CREATIONS LTD**  
55 Merthyr Terrace, Barnes, London SW13 9DL.  
Tel: 01-741 5747.  
Contact: Patric de Vaux, Sales. Lasers for lighting displays and installations featuring the series 9 state of the art controller as featured in the Hippodrome.
- LASER SYSTEMS LTD**  
Unit 11, Lanerham Park, Cwmbran, Gwent NP44 3AX.  
Tel: (06333) 62500/73222.
- LE MAITRE LIGHTING & EFFECTS**  
316 Purley Way, Croydon CR0 4XJ.  
Tel: 01-688 9258.  
Tel: 883220.  
Contact: Mick McKanus, Partner; Rodney Clark, Sales Manager. Manufacturers of pyrotechnics, smoke machines, lighting and other related products for the entertainment industries.
- LEAMINGTON SIGHT & SOUND**  
Unit 17, Kibby Close, Heartcore Ind. Estate, Leamington Spa, Warwick.  
Tel: (0926) 833617.
- LIGHT ENGINEERING LTD**  
64a Ecken Road, Walthamstow, London E17 9YF.  
Tel: 01-520 233677.  
Contact: Stephen Demeza, General Manager; Neil Preen, UK Sales Representative. Manufacture, supply and distribution to the trade of: sound, lighting and special effects. Specialists in installation and design.
- LIGHT SYSTEMS**  
Unit 3, Bartlett Court, Lynx Trading Estate, Yeovil, Somerset BA20 2PT.  
Tel: (0935) 26743.
- LIGHTFACTORY LTD**  
71 Farway Drive, Fairway Industrial Estate, Greenford, Middlesex UB6 8PW.  
Tel: 01-575 5566.
- LIGHTING AND SOUND SERVICES**  
237 Chester Road, Helsby, Cheshire W46 OAD.  
Tel: 092-82 3502.
- LUTON SOUND & LIGHTING LTD**  
75 & 82-88 Wellington Street, Luton, Bedfordshire LU1 5AA.  
Tel: (0582) 411733 (5 lines).
- CONTACT: Mike Henden, Sales Director**
- FANTASIA SOUND & LIGHTING**  
16 Chaltoners Hill, Steeple Claydon, Bucks.  
Tel: (0247) 462338.
- FANTASIA SOUND & LIGHTING**  
Northern Ireland BT19 2EX.  
9 Seabird Crescent, Bangor, Co. Down, NI.  
Tel: 01-240 3527.
- FORMULA SOUND LTD**  
Stuart Road, Ashton Road, Redbury, Stockport, Cheshire SK6 2SR.  
Tel: 061-494 5650.
- GENERAL ELECTRIC USA**  
10 Prospect Way, Royal Oak Industrial Estate, Daventry, Northants NN11 5PL.  
Tel: (0327) 77683.
- HARMAN (AUDIO) UK LTD**  
Mill Street, Slough, Berks.  
Tel: (0753) 76911.
- HAZEL GROVE MUSIC COMPANY LTD**  
Bulkeley House, Stockport Road, Cheshire, Cheshire SK8 2AA.  
Tel: (061-491) 1068.
- HILL AUDIO LTD**  
Hollingbourne House, Hollingbourne, Maidstone, Kent ME17 1QJ.  
Tel: (062 780) 555.
- ICELECTRICS LTD**  
22 Woolmer Way, Bordon, Hants GU35 9QF.  
Tel: (04203) 87128.
- MICO LIGHTING LTD**  
Troyle Lane, Pudsey, Leeds LS28 9LD.  
Tel: (0532) 567113.
- LASER CREATIONS LTD**  
55 Merthyr Terrace, Barnes, London SW13 9DL.  
Tel: 01-741 5747.  
Contact: Patric de Vaux, Sales. Lasers for lighting displays and installations featuring the series 9 state of the art controller as featured in the Hippodrome.
- LASER SYSTEMS LTD**  
Unit 11, Lanerham Park, Cwmbran, Gwent NP44 3AX.  
Tel: (06333) 62500/73222.
- LE MAITRE LIGHTING & EFFECTS**  
316 Purley Way, Croydon CR0 4XJ.  
Tel: 01-688 9258.  
Tel: 883220.  
Contact: Mick McKanus, Partner; Rodney Clark, Sales Manager. Manufacturers of pyrotechnics, smoke machines, lighting and other related products for the entertainment industries.
- LEAMINGTON SIGHT & SOUND**  
Unit 17, Kibby Close, Heartcore Ind. Estate, Leamington Spa, Warwick.  
Tel: (0926) 833617.
- LIGHT ENGINEERING LTD**  
64a Ecken Road, Walthamstow, London E17 9YF.  
Tel: 01-520 233677.  
Contact: Stephen Demeza, General Manager; Neil Preen, UK Sales Representative. Manufacture, supply and distribution to the trade of: sound, lighting and special effects. Specialists in installation and design.
- LIGHT SYSTEMS**  
Unit 3, Bartlett Court, Lynx Trading Estate, Yeovil, Somerset BA20 2PT.  
Tel: (0935) 26743.
- LIGHTFACTORY LTD**  
71 Farway Drive, Fairway Industrial Estate, Greenford, Middlesex UB6 8PW.  
Tel: 01-575 5566.
- LIGHTING AND SOUND SERVICES**  
237 Chester Road, Helsby, Cheshire W46 OAD.  
Tel: 092-82 3502.
- LUTON SOUND & LIGHTING LTD**  
75 & 82-88 Wellington Street, Luton, Bedfordshire LU1 5AA.  
Tel: (0582) 411733 (5 lines).
- CONTACT: Mike Henden, Sales Director**
- FANTASIA SOUND & LIGHTING**  
16 Chaltoners Hill, Steeple Claydon, Bucks.  
Tel: (0247) 462338.
- FANTASIA SOUND & LIGHTING**  
Northern Ireland BT19 2EX.  
9 Seabird Crescent, Bangor, Co. Down, NI.  
Tel: 01-240 3527.
- FORMULA SOUND LTD**  
Stuart Road, Ashton Road, Redbury, Stockport, Cheshire SK6 2SR.  
Tel: 061-494 5650.
- GENERAL ELECTRIC USA**  
10 Prospect Way, Royal Oak Industrial Estate, Daventry, Northants NN11 5PL.  
Tel: (0327) 77683.
- HARMAN (AUDIO) UK LTD**  
Mill Street, Slough, Berks.  
Tel: (0753) 76911.
- HAZEL GROVE MUSIC COMPANY LTD**  
Bulkeley House, Stockport Road, Cheshire, Cheshire SK8 2AA.  
Tel: (061-491) 1068.
- HILL AUDIO LTD**  
Hollingbourne House, Hollingbourne, Maidstone, Kent ME17 1QJ.  
Tel: (062 780) 555.
- ICELECTRICS LTD**  
22 Woolmer Way, Bordon, Hants GU35 9QF.  
Tel: (04203) 87128.
- MICO LIGHTING LTD**  
Troyle Lane, Pudsey, Leeds LS28 9LD.  
Tel: (0532) 567113.
- LASER CREATIONS LTD**  
55 Merthyr Terrace, Barnes, London SW13 9DL.  
Tel: 01-741 5747.  
Contact: Patric de Vaux, Sales. Lasers for lighting displays and installations featuring the series 9 state of the art controller as featured in the Hippodrome.
- LASER SYSTEMS LTD**  
Unit 11, Lanerham Park, Cwmbran, Gwent NP44 3AX.  
Tel: (06333) 62500/73222.
- LE MAITRE LIGHTING & EFFECTS**  
316 Purley Way, Croydon CR0 4XJ.  
Tel: 01-688 9258.  
Tel: 883220.  
Contact: Mick McKanus, Partner; Rodney Clark, Sales Manager. Manufacturers of pyrotechnics, smoke machines, lighting and other related products for the entertainment industries.
- LEAMINGTON SIGHT & SOUND**  
Unit 17, Kibby Close, Heartcore Ind. Estate, Leamington Spa, Warwick.  
Tel: (0926) 833617.
- LIGHT ENGINEERING LTD**  
64a Ecken Road, Walthamstow, London E17 9YF.  
Tel: 01-520 233677.  
Contact: Stephen Demeza, General Manager; Neil Preen, UK Sales Representative. Manufacture, supply and distribution to the trade of: sound, lighting and special effects. Specialists in installation and design.
- LIGHT SYSTEMS**  
Unit 3, Bartlett Court, Lynx Trading Estate, Yeovil, Somerset BA20 2PT.  
Tel: (0935) 26743.
- LIGHTFACTORY LTD**  
71 Farway Drive, Fairway Industrial Estate, Greenford, Middlesex UB6 8PW.  
Tel: 01-575 5566.
- LIGHTING AND SOUND SERVICES**  
237 Chester Road, Helsby, Cheshire W46 OAD.  
Tel: 092-82 3502.
- LUTON SOUND & LIGHTING LTD**  
75 & 82-88 Wellington Street, Luton, Bedfordshire LU1 5AA.  
Tel: (0582) 411733 (5 lines).
- CONTACT: Mike Henden, Sales Director**
- FANTASIA SOUND & LIGHTING**  
16 Chaltoners Hill, Steeple Claydon, Bucks.  
Tel: (0247) 462338.
- FANTASIA SOUND & LIGHTING**  
Northern Ireland BT19 2EX.  
9 Seabird Crescent, Bangor, Co. Down, NI.  
Tel: 01-240 3527.
- FORMULA SOUND LTD**  
Stuart Road, Ashton Road, Redbury, Stockport, Cheshire SK6 2SR.  
Tel: 061-494 5650.
- GENERAL ELECTRIC USA**  
10 Prospect Way, Royal Oak Industrial Estate, Daventry, Northants NN11 5PL.  
Tel: (0327) 77683.
- HARMAN (AUDIO) UK LTD**  
Mill Street, Slough, Berks.  
Tel: (0753) 76911.
- HAZEL GROVE MUSIC COMPANY LTD**  
Bulkeley House, Stockport Road, Cheshire, Cheshire SK8 2AA.  
Tel: (061-491) 1068.
- HILL AUDIO LTD**  
Hollingbourne House, Hollingbourne, Maidstone, Kent ME17 1QJ.  
Tel: (062 780) 555.
- ICELECTRICS LTD**  
22 Woolmer Way, Bordon, Hants GU35 9QF.  
Tel: (04203) 87128.
- MICO LIGHTING LTD**  
Troyle Lane, Pudsey, Leeds LS28 9LD.  
Tel: (0532) 567113.
- LASER CREATIONS LTD**  
55 Merthyr Terrace, Barnes, London SW13 9DL.  
Tel: 01-741 5747.  
Contact: Patric de Vaux, Sales. Lasers for lighting displays and installations featuring the series 9 state of the art controller as featured in the Hippodrome.
- LASER SYSTEMS LTD**  
Unit 11, Lanerham Park, Cwmbran, Gwent NP44 3AX.  
Tel: (06333) 62500/73222.
- LE MAITRE LIGHTING & EFFECTS**  
316 Purley Way, Croydon CR0 4XJ.  
Tel: 01-688 9258.  
Tel: 883220.  
Contact: Mick McKanus, Partner; Rodney Clark, Sales Manager. Manufacturers of pyrotechnics, smoke machines, lighting and other related products for the entertainment industries.
- LEAMINGTON SIGHT & SOUND**  
Unit 17, Kibby Close, Heartcore Ind. Estate, Leamington Spa, Warwick.  
Tel: (0926) 833617.
- LIGHT ENGINEERING LTD**  
64a Ecken Road, Walthamstow, London E17 9YF.  
Tel: 01-520 233677.  
Contact: Stephen Demeza, General Manager; Neil Preen, UK Sales Representative. Manufacture, supply and distribution to the trade of: sound, lighting and special effects. Specialists in installation and design.
- LIGHT SYSTEMS**  
Unit 3, Bartlett Court, Lynx Trading Estate, Yeovil, Somerset BA20 2PT.  
Tel: (0935) 26743.
- LIGHTFACTORY LTD**  
71 Farway Drive, Fairway Industrial Estate, Greenford, Middlesex UB6 8PW.  
Tel: 01-575 5566.
- LIGHTING AND SOUND SERVICES**  
237 Chester Road, Helsby, Cheshire W46 OAD.  
Tel: 092-82 3502.
- LUTON SOUND & LIGHTING LTD**  
75 & 82-88 Wellington Street, Luton, Bedfordshire LU1 5AA.  
Tel: (0582) 411733 (5 lines).
- CONTACT: Mike Henden, Sales Director**
- FANTASIA SOUND & LIGHTING**  
16 Chaltoners Hill, Steeple Claydon, Bucks.  
Tel: (0247) 462338.
- FANTASIA SOUND & LIGHTING**  
Northern Ireland BT19 2EX.  
9 Seabird Crescent, Bangor, Co. Down, NI.  
Tel: 01-240 3527.
- FORMULA SOUND LTD**  
Stuart Road, Ashton Road, Redbury, Stockport, Cheshire SK6 2SR.  
Tel: 061-494 5650.
- GENERAL ELECTRIC USA**  
10 Prospect Way, Royal Oak Industrial Estate, Daventry, Northants NN11 5PL.  
Tel: (0327) 77683.
- HARMAN (AUDIO) UK LTD**  
Mill Street, Slough, Berks.  
Tel: (0753) 76911.
- HAZEL GROVE MUSIC COMPANY LTD**  
Bulkeley House, Stockport Road, Cheshire, Cheshire SK8 2AA.  
Tel: (061-491) 1068.
- HILL AUDIO LTD**  
Hollingbourne House, Hollingbourne, Maidstone, Kent ME17 1QJ.  
Tel: (062 780) 555.
- ICELECTRICS LTD**  
22 Woolmer Way, Bordon, Hants GU35 9QF.  
Tel: (04203) 87128.
- MICO LIGHTING LTD**  
Troyle Lane, Pudsey, Leeds LS28 9LD.  
Tel: (0532) 567113.
- LASER CREATIONS LTD**  
55 Merthyr Terrace, Barnes, London SW13 9DL.  
Tel: 01-741 5747.  
Contact: Patric de Vaux, Sales. Lasers for lighting displays and installations featuring the series 9 state of the art controller as featured in the Hippodrome.
- LASER SYSTEMS LTD**  
Unit 11, Lanerham Park, Cwmbran, Gwent NP44 3AX.  
Tel: (06333) 62500/73222.
- LE MAITRE LIGHTING & EFFECTS**  
316 Purley Way, Croydon CR0 4XJ.  
Tel: 01-688 9258.  
Tel: 883220.  
Contact: Mick McKanus, Partner; Rodney Clark, Sales Manager. Manufacturers of pyrotechnics, smoke machines, lighting and other related products for the entertainment industries.
- LEAMINGTON SIGHT & SOUND**  
Unit 17, Kibby Close, Heartcore Ind. Estate, Leamington Spa, Warwick.  
Tel: (0926) 833617.
- LIGHT ENGINEERING LTD**  
64a Ecken Road, Walthamstow, London E17 9YF.  
Tel: 01-520 233677.  
Contact: Stephen Demeza, General Manager; Neil Preen, UK Sales Representative. Manufacture, supply and distribution to the trade of: sound, lighting and special effects. Specialists in installation and design.
- LIGHT SYSTEMS**  
Unit 3, Bartlett Court, Lynx Trading Estate, Yeovil, Somerset BA20 2PT.  
Tel: (0935) 26743.
- LIGHTFACTORY LTD**  
71 Farway Drive, Fairway Industrial Estate, Greenford, Middlesex UB6 8PW.  
Tel: 01-575 5566.
- LIGHTING AND SOUND SERVICES**  
237 Chester Road, Helsby, Cheshire W46 OAD.  
Tel: 092-82 3502.
- LUTON SOUND & LIGHTING LTD**  
75 & 82-88 Wellington Street, Luton, Bedfordshire LU1 5AA.  
Tel: (0582) 411733 (5 lines).
- CONTACT: Mike Henden, Sales Director**
- FANTASIA SOUND & LIGHTING**  
16 Chaltoners Hill, Steeple Claydon, Bucks.  
Tel: (0247) 462338.
- FANTASIA SOUND & LIGHTING**  
Northern Ireland BT19 2EX.  
9 Seabird Crescent, Bangor, Co. Down, NI.  
Tel: 01-240 3527.
- FORMULA SOUND LTD**  
Stuart Road, Ashton Road, Redbury, Stockport, Cheshire SK6 2SR.  
Tel: 061-494 5650.
- GENERAL ELECTRIC USA**  
10 Prospect Way, Royal Oak Industrial Estate, Daventry, Northants NN11 5PL.  
Tel: (0327) 77683.
- HARMAN (AUDIO) UK LTD**  
Mill Street, Slough, Berks.  
Tel: (0753) 76911.
- HAZEL GROVE MUSIC COMPANY LTD**  
Bulkeley House, Stockport Road, Cheshire, Cheshire SK8 2AA.  
Tel: (061-491) 1068.
- HILL AUDIO LTD**  
Hollingbourne House, Hollingbourne, Maidstone, Kent ME17 1QJ.  
Tel: (062 780) 555.
- ICELECTRICS LTD**  
22 Woolmer Way, Bordon, Hants GU35 9QF.  
Tel: (04203) 87128.
- MICO LIGHTING LTD**  
Troyle Lane, Pudsey, Leeds LS28 9LD.  
Tel: (0532) 567113.
- LASER CREATIONS LTD**  
55 Merthyr Terrace, Barnes, London SW13 9DL.  
Tel: 01-741 5747.  
Contact: Patric de Vaux, Sales. Lasers for lighting displays and installations featuring the series 9 state of the art controller as featured in the Hippodrome.
- LASER SYSTEMS LTD**  
Unit 11, Lanerham Park, Cwmbran, Gwent NP44 3AX.  
Tel: (06333) 62500/73222.
- LE MAITRE LIGHTING & EFFECTS**  
316 Purley Way, Croydon CR0 4XJ.  
Tel: 01-688 9258.  
Tel: 883220.  
Contact: Mick McKanus, Partner; Rodney Clark, Sales Manager. Manufacturers of pyrotechnics, smoke machines, lighting and other related products for the entertainment industries.
- LEAMINGTON SIGHT & SOUND**  
Unit 17, Kibby Close, Heartcore Ind. Estate, Leamington Spa, Warwick.  
Tel: (0926) 833617.
- LIGHT ENGINEERING LTD**  
64a Ecken Road, Walthamstow, London E17 9YF.  
Tel: 01-520 233677.  
Contact: Stephen Demeza, General Manager; Neil Preen, UK Sales Representative. Manufacture, supply and distribution to the trade of: sound, lighting and special effects. Specialists in installation and design.
- LIGHT SYSTEMS**  
Unit 3, Bartlett Court, Lynx Trading Estate, Yeovil, Somerset BA20 2PT.  
Tel: (0935) 26743.
- LIGHTFACTORY LTD**  
71 Farway Drive, Fairway Industrial Estate, Greenford, Middlesex UB6 8PW.  
Tel: 01-575 5566.
- LIGHTING AND SOUND SERVICES**  
237 Chester Road, Helsby, Cheshire W46 OAD.  
Tel: 092-82 3502.
- LUTON SOUND & LIGHTING LTD**  
75 & 82-88 Wellington Street, Luton, Bedfordshire LU1 5AA.  
Tel: (0582) 411733 (5 lines).
- CONTACT: Mike Henden, Sales Director**
- FANTASIA SOUND & LIGHTING**  
16 Chaltoners Hill, Steeple Claydon, Bucks.  
Tel: (0247) 462338.
- FANTASIA SOUND & LIGHTING**  
Northern Ireland BT19 2EX.  
9 Seabird Crescent, Bangor, Co. Down, NI.  
Tel: 01-240 3527.
- FORMULA SOUND LTD**  
Stuart Road, Ashton Road, Redbury, Stockport, Cheshire SK6 2SR.  
Tel: 061-494 5650.
- GENERAL ELECTRIC USA**  
10 Prospect Way, Royal Oak Industrial Estate, Daventry, Northants NN11 5PL.  
Tel: (0327) 77683.
- HARMAN (AUDIO) UK LTD**  
Mill Street, Slough, Berks.  
Tel: (0753) 76911.
- HAZEL GROVE MUSIC COMPANY LTD**  
Bulkeley House, Stockport Road, Cheshire, Cheshire SK8 2AA.  
Tel: (061-491) 1068.
- HILL AUDIO LTD**  
Hollingbourne House, Hollingbourne, Maidstone, Kent ME17 1QJ.  
Tel: (062 780) 555.
- ICELECTRICS LTD**  
22 Woolmer Way, Bordon, Hants GU35 9QF.  
Tel: (04203) 87128.
- MICO LIGHTING LTD**  
Troyle Lane, Pudsey, Leeds LS28 9LD.  
Tel: (0532) 567113.
- LASER CREATIONS LTD**  
55 Merthyr Terrace, Barnes, London SW13 9DL.  
Tel: 01-741 5747.  
Contact: Patric de Vaux, Sales. Lasers for lighting displays and installations featuring the series 9 state of the art controller as featured in the Hippodrome.
- LASER SYSTEMS LTD**  
Unit 11, Lanerham Park, Cwmbran, Gwent NP44 3AX.  
Tel: (06333) 62500/73222.
- LE MAITRE LIGHTING & EFFECTS**  
316 Purley Way, Croydon CR0 4XJ.  
Tel: 01-688 9258.  
Tel: 883220.  
Contact: Mick McKanus, Partner; Rodney Clark, Sales Manager. Manufacturers of pyrotechnics, smoke machines, lighting and other related products for the entertainment industries.
- LEAMINGTON SIGHT & SOUND**  
Unit 17, Kibby Close, Heartcore Ind. Estate, Leamington Spa, Warwick.  
Tel: (0926) 833617.
- LIGHT ENGINEERING LTD**  
64a Ecken Road, Walthamstow, London E17 9YF.  
Tel: 01-520 233677.  
Contact: Stephen Demeza, General Manager; Neil Preen, UK Sales Representative. Manufacture, supply and distribution to the trade of: sound, lighting and special effects. Specialists in installation and design.
- LIGHT SYSTEMS**  
Unit 3, Bartlett Court, Lynx Trading Estate, Yeovil, Somerset BA20 2PT.  
Tel: (0935) 26743.
- LIGHTFACTORY LTD**  
71 Farway Drive, Fairway Industrial Estate, Greenford, Middlesex UB6 8PW.  
Tel: 01-575 5566.
- LIGHTING AND SOUND SERVICES**  
237 Chester Road, Helsby, Cheshire W46 OAD.  
Tel: 092-82 3502.
- LUTON SOUND & LIGHTING LTD**  
75 & 82-88 Wellington Street, Luton, Bedfordshire LU1 5AA.  
Tel: (0582) 411733 (5 lines).
- CONTACT: Mike Henden, Sales Director**
- FANTASIA SOUND & LIGHTING**  
16 Chaltoners Hill, Steeple Claydon, Bucks.  
Tel: (



**POWERHOUSE HIRE****(Rainbow Discotheques)**

247 Oakleigh Road North, Whetstone,  
London N20 0TX.

Tel: 01-361 1144.

Hirers of: mobile dance floors, SL1200 turntables and special effects lighting.

**PULSAR LIGHT OF CAMBRIDGE LTD.**

Henley Road, Cambridge CB1 3EA.

Tel: (0223) 66798.

**Contact:** Derrick Saunders, Director; Ken Sewell, Director.

Manufacturers of lighting equipment for stage, discotheques. Products include dimmers, control desks, effects controllers, strobes, stage lanterns, disco spots, etc.

**R.K. LIGHTING LTD.**

4 Steep Hill, London SW16 1UL.

Tel: 01-769 5714.

**ROSCOLAB LIMITED**

69-71 Upper Ground, London SE1 9PQ.

Tel: 01-633 9220.

**ROSSULA LTD.**

11 Fairway Drive, Fairway Industrial Estate,

Greenford, Middlesex UB6 8PW.

Tel: 01-575 5566.

**SATEL (UK) LIMITED**

Unit 2, Merseyton Road, Ellesmere Port,

South Wirral L65 2HQ.

Tel: 051-355 6494.

**SCOTT SOUND SYSTEMS**

78 Sheffield Road, Barnsley,

South Yorkshire S70 1HX.

Tel: (0226) 290264.

**SHIPLEY DIAL LIMITED**

Unit 4C, Wharfedale Road, Euroway

Industrial Estate, Bradford BD4 6SG.

Tel: (0274) 687605.

**Contact:** Andy Blackwell (managing director) or Kris Blackwell (company secretary).

**SIS LTD.**

15/33 Gray Street, Northampton

NN1 3QQ.

Tel: (0604) 250025.

**Contact:** D.P. Mitchell, Managing Director. Manufacturers and Wholesalers of Quality Discotheque Equipment to the Trade.

**SLICK SYSTEMS**

Portland Street North, Leek,

Staffs. ST13 6LA.

Tel: (0538) 381315.

**SOFSCOTECH SYSTEMS LTD.**

1212 Leeds Road, Bradford, West Yorks

BD3 8JL.

Tel: (0274) 661406.

**SOUND CREATIONS**

Disco Power (1980) Ltd.

8 Britannia Road, Worcester WR1 5BQ.

Tel: (0905) 21707.

**SOUND ELECTRONICS LTD.**

124 Junction Road, London N19 5LB.

Tel: 01-272 6044.

**SOUNDTECH LTD.**

137 Western Road, Hockley,

Birmingham B18 7QD.

Tel: 021-523 6344.

**SQUIRE LIGHT & SOUND LTD.**

Knight House, 29/31 East Barnet Road,

Barnet, Herts EN4 8RN.

Tel: 01-449 5169.

Branches in London, Birmingham, Glasgow and Manchester.

**STAGE TWO LTD.**

197 Watford Road, Croxley Green,

Herts WD3 3EH.

Tel: (0923) 30789

**STARDREAM AUDIO VISUAL LTD**

Party House, Mowbray Drive, Blackpool

FY3 7JR.

Tel: (0253) 302602.

**STARLIGHT DESIGN**

9 Alms Hill, Bourn, Cambs CB3 7SH.

Tel: (09544) 8841.

**STRAND LIGHTING**

PO Box 51, Great West Road, Brentford,

Middlesex TW8 9HR.

Tel: 01-560 3171.

**SUPERMICK LIGHTS**

119-121 Freston Road, Holland Park,

London W11 4BD.

Tel: 01-221 2322.

**Contact:** Peter Clarke, proprietor or Dick Beaumont.

**TANNOY LIMITED**

The Bilton Centre, Coronation Road,

Cressex Industrial Estate, High Wycombe,

Bucks.

Tel: (0494) 450606.

**Contact:** Martin Bailey, U.K. Sales Manager. Design and manufacture of studio monitors, hi-fi loudspeakers and live music PA loudspeakers.

**TEC LIMITED**

1 St. Paul's Square, Birmingham,

West Midlands B3 1QU.

Tel: 021-233 4262.

**TK LIGHT & SOUND LTD.**

18 Douglas Road, Croydon, Ayr KA6 6JJ.

Tel: (0292) 281655.

**TOBYSOUND LTD.**

137 High Street, Burton-on-Trent, Staffs

DE14 1JZ.

Tel: (0283) 45301.

**Contacts:** Steve Halsall (product manager)

or Paul Eaton (assistant product manager).

Full installation service. Also main

distributor for Quatro lighting controller.

**TURBOSOUND LIMITED**

202 New North Road, London N1 7BL.

Tel: 01-226 0099.

**VITAVOX LIMITED**

5 Elstree Way, Borehamwood, Herts

WD6 1SF.

Tel: 01-953 4151

**W.B. LIGHTING LIMITED T/A COEMAR (UK)**

4 Tenter Road, Moulton Park Industrial

Estate, Northampton NN3 1PZ.

Tel: (0604) 499331.

**Contact:** Roman Walanta, Director.

Suppliers of lighting to the entertainment industry.

**WATKINS ELECTRIC MUSIC LTD.**

Unit 119, 62 Triton Road,

London SE21 8DE.

Tel: 01-735 6565.

Cables: MUTELTRIC, LONDON.

**Contact:** C. Watkins, Managing Director; B.

McLaren, Chief Engineer; A. Watkins,

Manager.

Manufacturer of loudspeakers.

Loudspeaker cabinets. Amplifiers.

**WEMBLEY LOUDSPEAKER CO. LTD**

75 Jeddo Road, London W12 9ED.

Tel: 01-743 4567.

**WHARFEDALE LIMITED**

Sandleas Way, Crossgates, Leeds,

West Yorks. LS15 8AL.

Tel: (0532) 601222.

**WILMEX LTD.**

Compton House, 35 High Street, New

Malden, Surrey.

Tel: 01-949 2545.

**Contact:** Peter Merrick, Managing Director;

Clive Lincoln, Sales Manager.

Distribution - Stanton pro-disco cartridges

+ styli. Ramsa professional loudspeakers.

Monster professional loudspeaker cable

and connectors.

**WYNNE WILLSON GOTTELLIER LTD**

The Old Mission House, Ide Hill,

Sevenoaks, Kent TN13 6BZ.

Tel: (0732) 75204.

**ZERO 88 LIGHTING LTD.**

Hart Road, St. Albans, Herts AL1 1NA.

Tel: (0727) 33271.

**Contact:** David Catterall, UK Sales Ex-

ecutive; Freddy Lloyd, Sales Director.

Specialist manufacturers of advanced

technology lighting controllers for both the

club and theatre market.



# Light & Sound Show

11-14 September



## Olympia 2

The new home of the Light & Sound Show for the 1988 event is one of London's newest, purpose designed exhibition halls. It combines all the comfort a hotel venue gives with the practicality conventional exhibition halls offer. Its size has enabled PLASA to answer demands of the industry by doubling the size of the exhibition without losing the friendliness characteristic of the Light & Sound Show.

Sponsored by



For more information on the 88 Light & Sound Show contact

David Street

10 Barley Mow Passage Chiswick London W4 4PH  
Telephone 01-994 6477 International +44 1 994 6477



PROFESSIONAL LIGHTING  
AND SOUND ASSOCIATION

**For a PLASA membership application form  
please write to:**

Tony Andrew, Secretary to the Association  
Professional Lighting and Sound Association  
7 Highlight House, St. Leonards Road, Eastbourne, Sussex BN21 3UH  
Telephone: (0323) 410335

# SMALLER-FASTER-LIGHTER



**SMALLER** Introducing Avolites Gellert — the smallest PAR64 scrolling colour changer ever produced. At 25 x 25 x 5cm focusing will never again be compromised by bulk.

**FASTER** Gellert is faster — up to 15 separate colours can be accessed from the gel stream in less than two seconds.

**LIGHTER** Weighing nearly half as much as other scrolling colour changers, at under a kilo Gellert means easier handling, mounting and fixture focusing.

It's smarter too! Gellert recognizes both analog control signals and industry standard digital protocols, and in the event of power loss, Gellert works with you to reset and relocate the exact positions you desire.

When you specify Gellert, you're selecting today's most advanced and reliable scrolling colour changer. And with Gellert you also have the Avolites assurance of immediate service response the world over.

